

REINFORCING STEEL PLACING DRAWING ONLY. USE IN CONJUNCTION WITH CONTRACT DRAWINGS & SPECIFICATIONS. ELEVATIONS & DIMENSIONS SHOWN ON DRAWING ARE FOR DETAILING PURPOSES ONLY AND SHOULD NOT BE USED FOR CONSTRUCTION UNLESS VERIFIED BY ENGINEER OR CONTRACTOR.

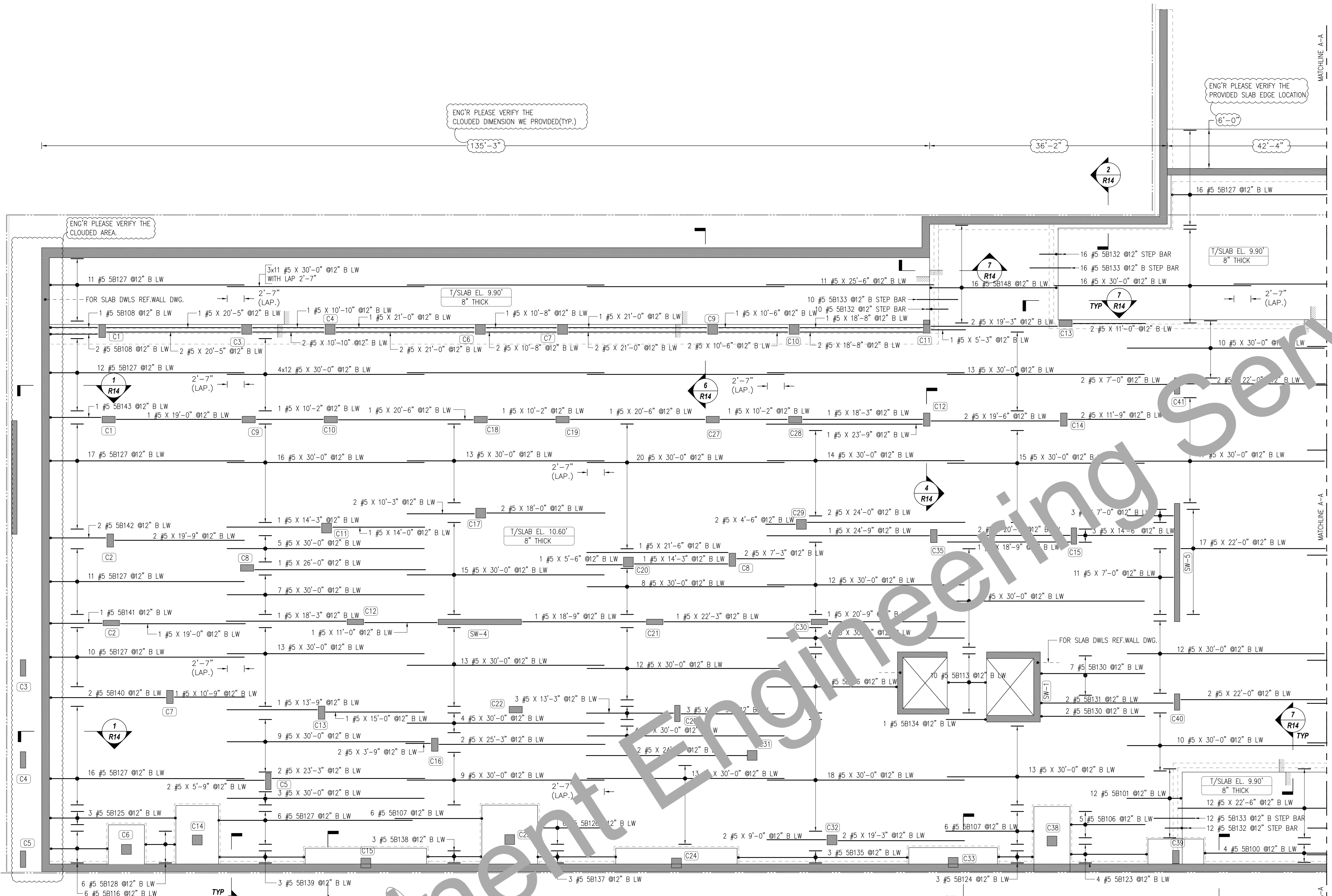

Bar Work	Qty	Size	Total Length	Type	X	Y	Z	W	V	U	T	S	R	Q	P	O	N	M	L	K	J	I	H	G	F	E	D	C	B	A	
5B100	4	#5	19'-0"	17																											
5B101	13	#5	8'-0"	17																											
5B106	3	#5	11'-0"	17																											
5B107	13	#5	15'-0"	17																											
5B108	3	#5	7'-0"	17																											
5B113	10	#5	6'-0"	17																											
5B116	4	#5	9'-0"	17																											
5B123	4	#5	12'-0"	17																											
5B124	3	#5	6'-0"	17																											
5B125	3	#5	6'-0"	17																											
5B126	6	#5	10'-0"	17																											
5B127	99	#5	30'-0"	17																											
5B128	8	#5	15'-0"	17																											
5B131	2	#5	20'-0"	17																											
5B132	38	#5	6'-0"	17																											
5B133	38	#5	6'-0"	17																											
5B134	1	#5	4'-0"	17																											
5B135	1	#5	26'-0"	17																											
5B136	1	#5	20'-0"	17																											
5B137	3	#5	12'-0"	17																											
5B138	3	#5	9'-0"	17																											
5B139	3	#5	13'-0"	17																											
5B140	2	#5	18'-0"	17																											
5B141	1	#5	8'-0"	17																											
5B142	3	#5	8'-0"	17																											
5B143	1	#5	8'-0"	17																											
5B148	16	#5	20'-0"	17																											

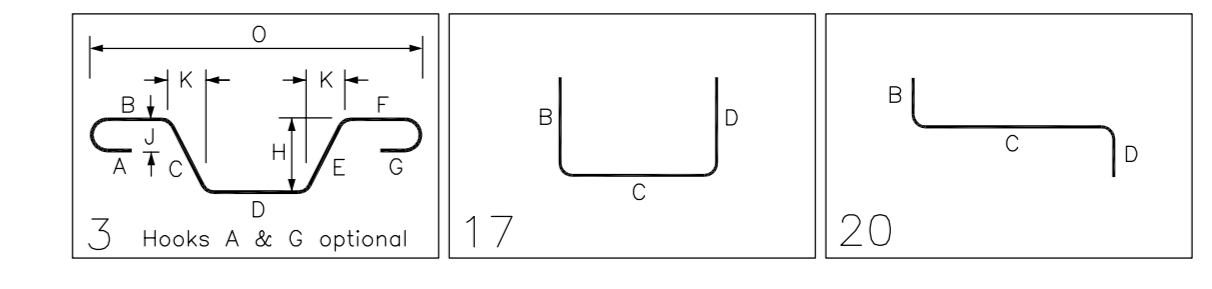

**LEVEL -1 SLAB ON GRADE BOTTOM LONG WAY BARS**

SCALE: 1/8"=1'-0"  
SDR: FO-001.00, FO-101.00 & FO-102.00, FO-201.00 & FO-202.00.

LAP NOTES:  
LAP VALUES AS PER SHEET NO. FO-001.00

CLASS	B	LAP	4000	PSI	FOR	SLAB
SIZE	TOP	OTHERS				
#3	24"	19"				
#4	32"	25"				
#5	40"	31"				
#6	48"	37"				
#7	70"	54"				
#8	80"	62"				
#9	91"	70"				
#10	102"	79"				
#11	113"	87"				

FOR APPROVAL

- NOTES:  
1. TOP OF SOG LEVEL REFER PLAN  
2. COVER DETAILS:  
FOR SOG: BOT = 3/4", TOP = 3/4" & SIDES = 2"  
3. STOCK LENGTH USED IS 30'-0"

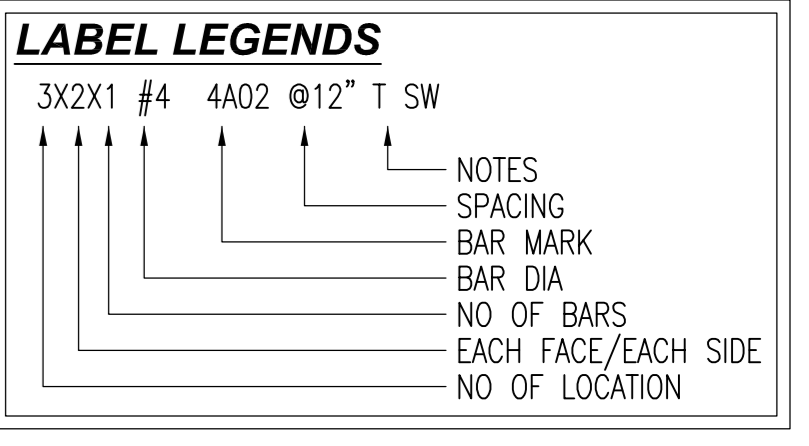

REFERENCE DRAWINGS  
FOR REBAR DETAIL OF LEVEL-1 SLAB ON GRADE TOP LONG WAY REFER DRAWING #R07  
FOR REBAR DETAIL OF LEVEL-1 SLAB ON GRADE TOP SHORT WAY REFER DRAWING #R08  
FOR REBAR DETAIL OF LEVEL-1 SLAB ON GRADE BOTTOM LONG WAY REFER DRAWING #R11  
FOR REBAR DETAIL OF LEVEL-1 SLAB ON GRADE BOTTOM SHORT WAY REFER DRAWING #R12  
FOR REBAR DETAIL OF LEVEL-1 SLAB ON GRADE SECTIONS REFER DRAWING #R14

REINFORCING STEEL PLACING DRAWING ONLY. USE IN CONJUNCTION WITH CONTRACT DRAWINGS & SPECIFICATIONS. ELEVATIONS & DIMENSIONS SHOWN ON DRAWING ARE FOR DETAILING PURPOSES ONLY AND SHOULD NOT BE USED FOR CONSTRUCTION UNLESS VERIFIED BY ENGINEER OR CONTRACTOR.

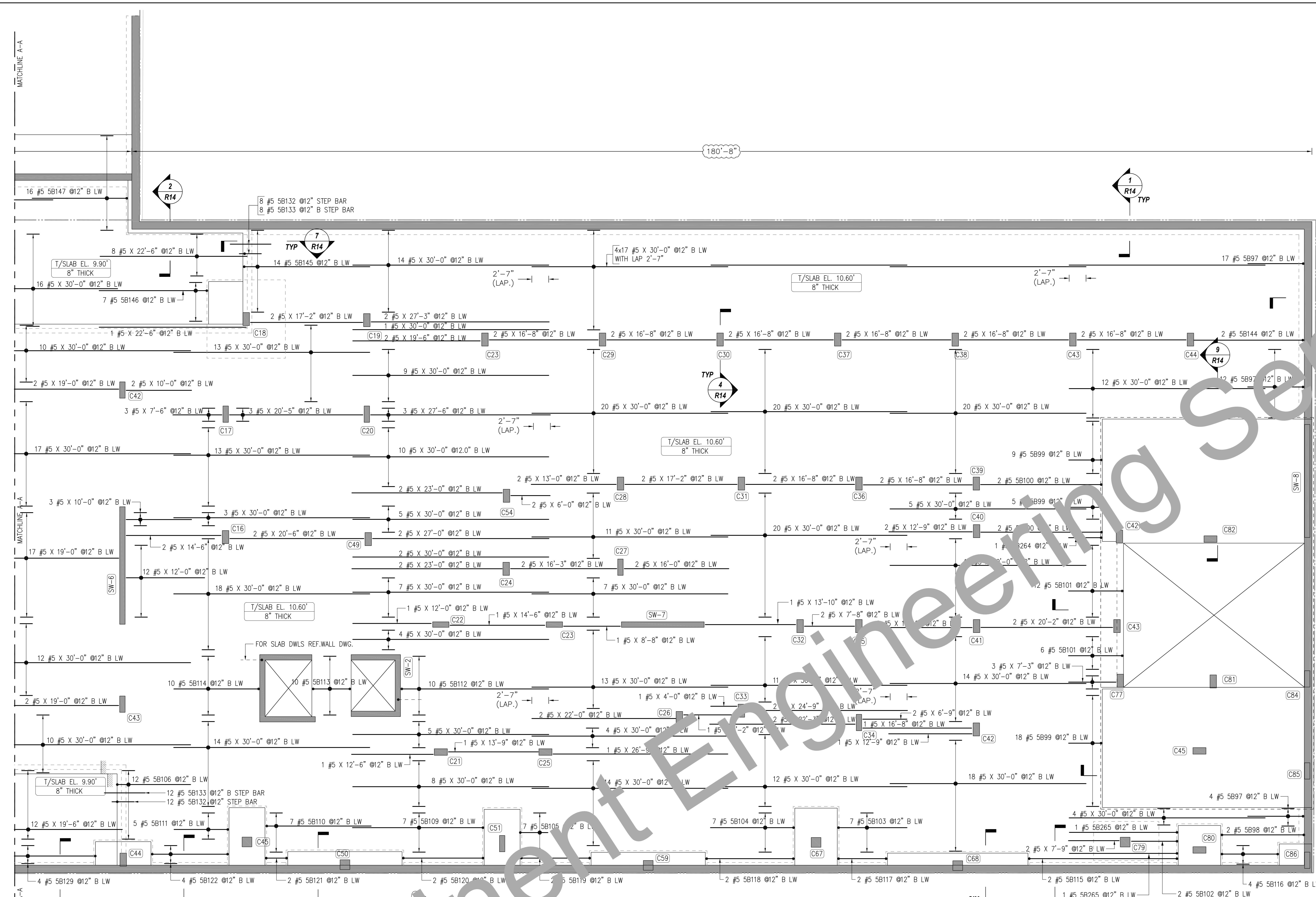

Bar Mark	Qty	Size	Total Length	Type	X	Y	Z	U	V	W	X	Y	Z	U	V	W	X	Y	Z	
5897	33	#5	9'-0"	17																
5898	2	#5	15'-7"	17																
5899	30	#5	5'-6"	17																
58100	4	#5	19'-0"	17																
58101	16	#5	8'-9"	17																
58102	2	#5	7'-4"	17																
58103	7	#5	11'-0"	17																
58104	7	#5	15'-3"	17																
58105	7	#5	4'-9"	17																
58106	12	#5	11'-7"	17																
58109	7	#5	20'-0"	17																
58110	7	#5	16'-0"	17																
58111	5	#5	8'-3"	17																
58113	10	#5	13'-0"	17																
58114	10	#5	6'-8"	17																
58115	20	#5	2'-9"	17																
58116	4	#5	8'-7"	17																
58117	1	#5	16'-0"	17																
58119	2	#5	14'-4"	17																
58119	2	#5	11'-6"	17																
58120	2	#5	15'-3"	17																
58121	2	#5	4'-2"	17																
58122	4	#5	12'-7"	17																
58129	4	#5	16'-0"	17																
58132	20	#5	4'-6"	20																
58133	20	#5	6'-8"	3																
58144	2	#5	17'-2"	17																
58145	14	#5	19'-5"	17																
58146	7	#5	17'-0"	17																
58147	16	#5	15'-0"	17																

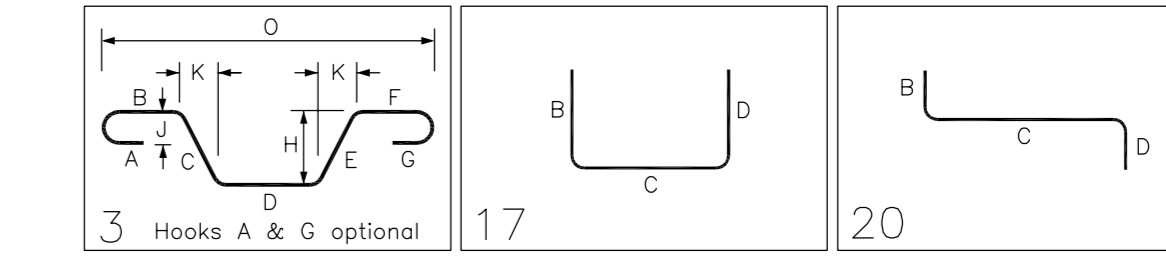

**LEVEL -1 SLAB ON GRADE BOTTOM LONG WAY BARS**

SCALE: 1/8"=1'-0"  
SDR: FO-001.00, FO-101.00 & FO-102.00, FO-201.00 & FO-202.00.

FOR APPROVAL

LAP NOTES:  
LAP VALUES AS PER SHEET NO. FO-001.00

CLASS	B	LAP	4000	PSI
FOR SLAB				
SIZE	TOP	OTHERS		
#3	24"	19"		
#4	32"	25"		
#5	40"	31"		
#6	48"	37"		
#7	70"	54"		
#8	80"	62"		
#9	91"	70"		
#10	102"	79"		
#11	113"	87"		

- NOTES:**
- TOP OF SOG LEVEL REFER PLAN
  - COVER DETAILS:  
FOR SOG: BOT = 3/4", TOP = 3/4" & SIDES = 2"
  - STOCK LENGTH USED IS 30'-0"

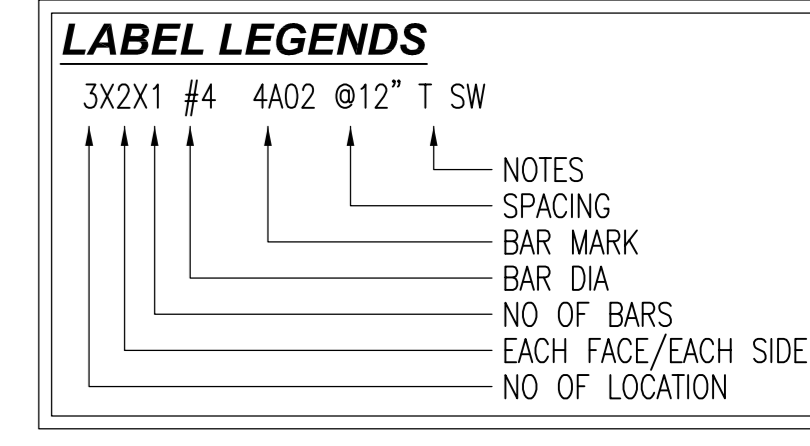

REFERENCE DRAWINGS

- FOR REBAR DETAIL OF LEVEL-1 SLAB ON GRADE TOP LONG WAY REFER DRAWING #R06
- FOR REBAR DETAIL OF LEVEL-1 SLAB ON GRADE TOP SHORT WAY REFER DRAWING #R08
- FOR REBAR DETAIL OF LEVEL-1 SLAB ON GRADE TOP SHORT WAY REFER DRAWING #R09
- FOR REBAR DETAIL OF LEVEL-1 SLAB ON GRADE BOTTOM LONG WAY REFER DRAWING #R10
- FOR REBAR DETAIL OF LEVEL-1 SLAB ON GRADE BOTTOM LONG WAY REFER DRAWING #R11
- FOR REBAR DETAIL OF LEVEL-1 SLAB ON GRADE BOTTOM SHORT WAY REFER DRAWING #R12
- FOR REBAR DETAIL OF LEVEL-1 SLAB ON GRADE BOTTOM SHORT WAY REFER DRAWING #R13
- FOR REBAR DETAIL OF LEVEL-1 SLAB ON GRADE SECTIONS REFER DRAWING #R14



REINFORCING STEEL PLACING DRAWING ONLY. USE IN CONJUNCTION WITH CONTRACT DRAWINGS & SPECIFICATIONS. ELEVATIONS & DIMENSIONS SHOWN ON DRAWING ARE FOR DETAILING PURPOSES ONLY AND SHOULD NOT BE USED FOR CONSTRUCTION UNLESS VERIFIED BY ENGINEER OR CONTRACTOR.

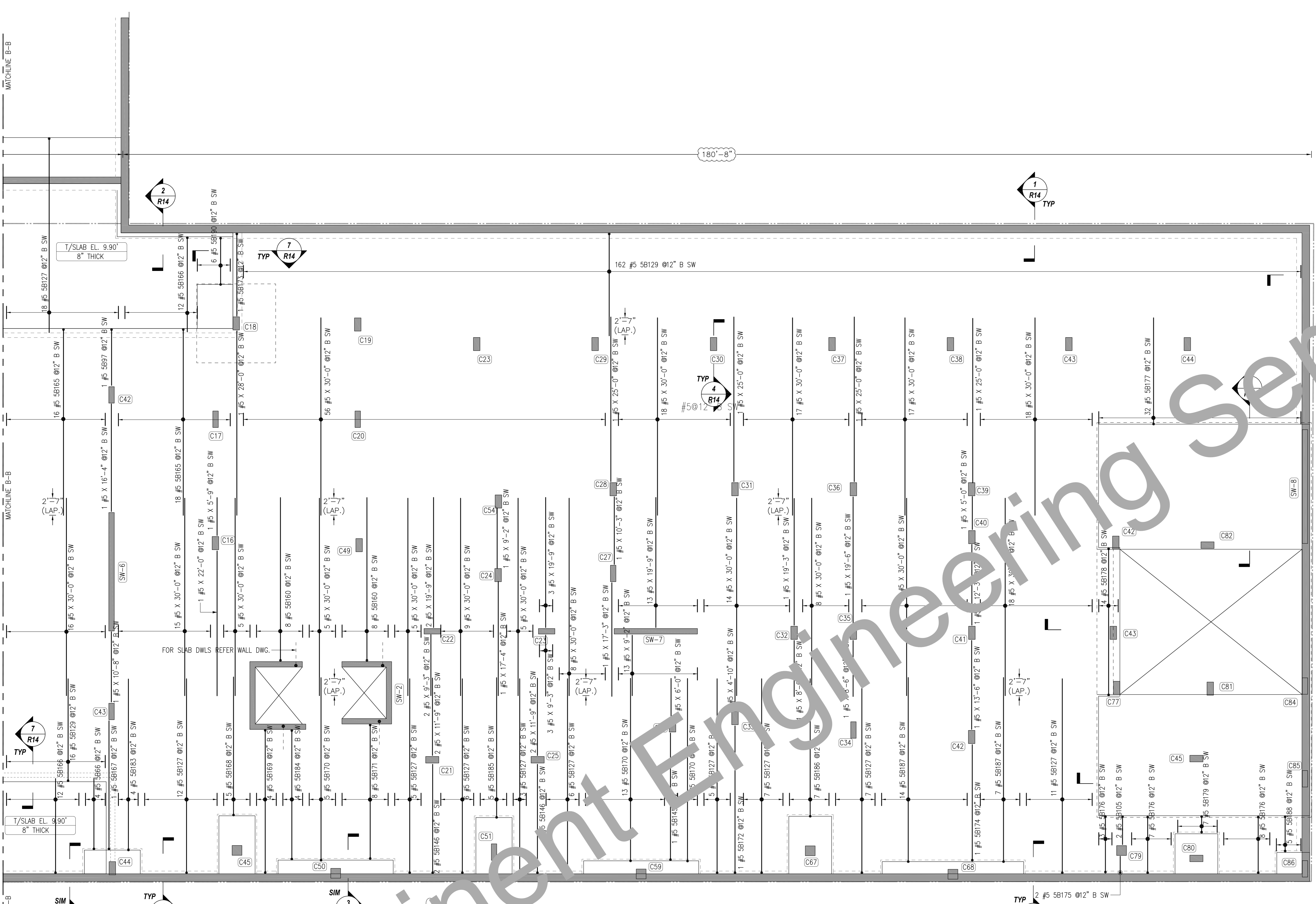

Bar Number	Qty	Total Length	Type	X	Y	Z	W	V	U	T	S	R	Q	P	O	N	M	L	K	J	I	H	G	F	E	D	C	B	A	
5897	1	11'-3"	17		0'-6"																									
5898	1	9'-0"	17		0'-6"																									
5899	2	4'-3"	17		0'-6"																									
5900	80	37'-0"	17		0'-6"																									
5901	138	65	18'-0"	17		0'-6"																								
5902	1	19'-5"	17		0'-6"																									
5903	4	17'-0"	17		0'-6"																									
5904	16	25'-3"	17		0'-6"																									
5905	34	28'-3"	17		0'-6"																									
5906	24	14'-0"	17		0'-6"																									
5907	1	20'-4"	17		0'-6"																									
5908	5	21'-4"	17		0'-6"																									
5909	4	22'-4"	17		0'-6"																									
5910	22	28'-3"	17		0'-6"																									
5911	8	37'-4"	17		0'-6"																									
5912	1	22'-10"	17		0'-6"																									
5913	1	15'-0"	17		0'-6"																									
5914	1	18'-1"	17		0'-6"																									
5915	2	3'-0"	17		0'-6"																									
5916	18	8'-4"	17		0'-6"																									
5917	20	14'-4"	17		0'-6"																									
5918	4	23'-3"	17		0'-6"																									
5919	7	5'-5"	17		0'-6"																									
5920	4	26'-4"	17		0'-6"																									
5921	4	19'-7"	17		0'-6"																									
5922	5	27'-4"	17		0'-6"																									
5923	7	15'-5"	17		0'-6"																									
5924	21	38'-4"	17		0'-6"																									
5925	5	6'-3"	17		0'-6"																									
5926	6	8'-1"	17		0'-6"																									

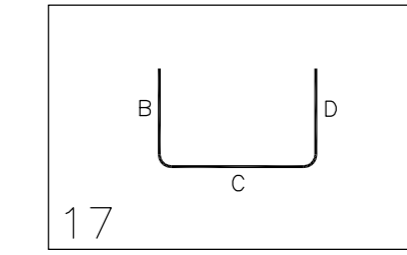

LAP NOTES:  
LAP VALUES AS PER SHEET NO. FO-001.00

CLASS B LAP 4000 PSI FOR SLAB

SIZE	TOP	OTHERS
#3	24"	19"
#4	32"	25"
#5	40"	31"
#6	48"	37"
#7	70"	54"
#8	80"	62"
#9	91"	70"
#10	102"	79"
#11	113"	87"

FOR APPROVAL

NOTES:  
1. TOP OF SOG LEVEL REFER PLAN  
2. COVER DETAILS:  
FOR SOG: BOT = 3/4", TOP = 3/4" & SIDES = 2"  
3. STOCK LENGTH USED IS 30'-0"

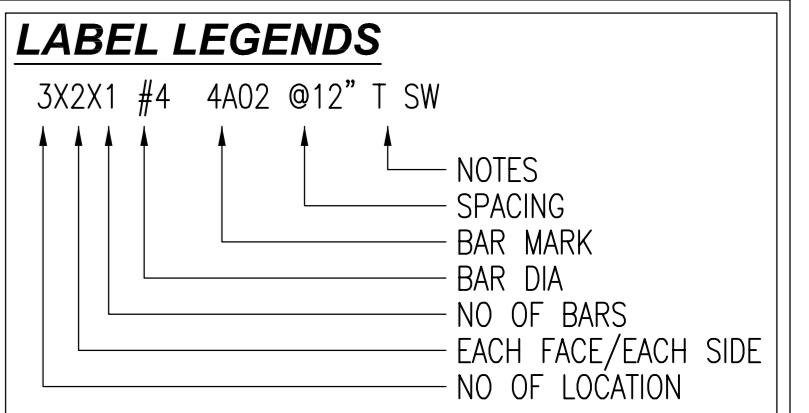

REFERENCE DRAWINGS

FOR REBAR DETAIL OF LEVEL-1 SLAB ON GRADE TOP LONG WAY REFER DRAWING #R06  
FOR REBAR DETAIL OF LEVEL-1 SLAB ON GRADE TOP LONG WAY REFER DRAWING #R07  
FOR REBAR DETAIL OF LEVEL-1 SLAB ON GRADE TOP SHORT WAY REFER DRAWING #R08  
FOR REBAR DETAIL OF LEVEL-1 SLAB ON GRADE BOTTOM LONG WAY REFER DRAWING #R10  
FOR REBAR DETAIL OF LEVEL-1 SLAB ON GRADE BOTTOM LONG WAY REFER DRAWING #R11  
FOR REBAR DETAIL OF LEVEL-1 SLAB ON GRADE BOTTOM SHORT WAY REFER DRAWING #R12  
FOR REBAR DETAIL OF LEVEL-1 SLAB ON GRADE BOTTOM SHORT WAY REFER DRAWING #R13  
FOR REBAR DETAIL OF LEVEL-1 SLAB ON GRADE SECTIONS REFER DRAWING #R14

LEVEL -1 SLAB ON GRADE BOTTOM SHORT WAY BARS

SCALE: 1/8"=1'-0"  
SDR: FO-001.00, FO-101.00 & FO-102.00, FO-201.00 & FO-202.00.

Eminent Engineering Services

**REINFORCING STEEL PLACING DRAWING ONLY. USE IN CONJUNCTION WITH CONTRACT DRAWINGS & SPECIFICATIONS. ELEVATIONS & DIMENSIONS SHOWN ON DRAWING ARE FOR DETAILING PURPOSES ONLY AND SHOULD NOT BE USED FOR CONSTRUCTION UNLESS VERIFIED BY ENGINEER OR CONTRACTOR.**

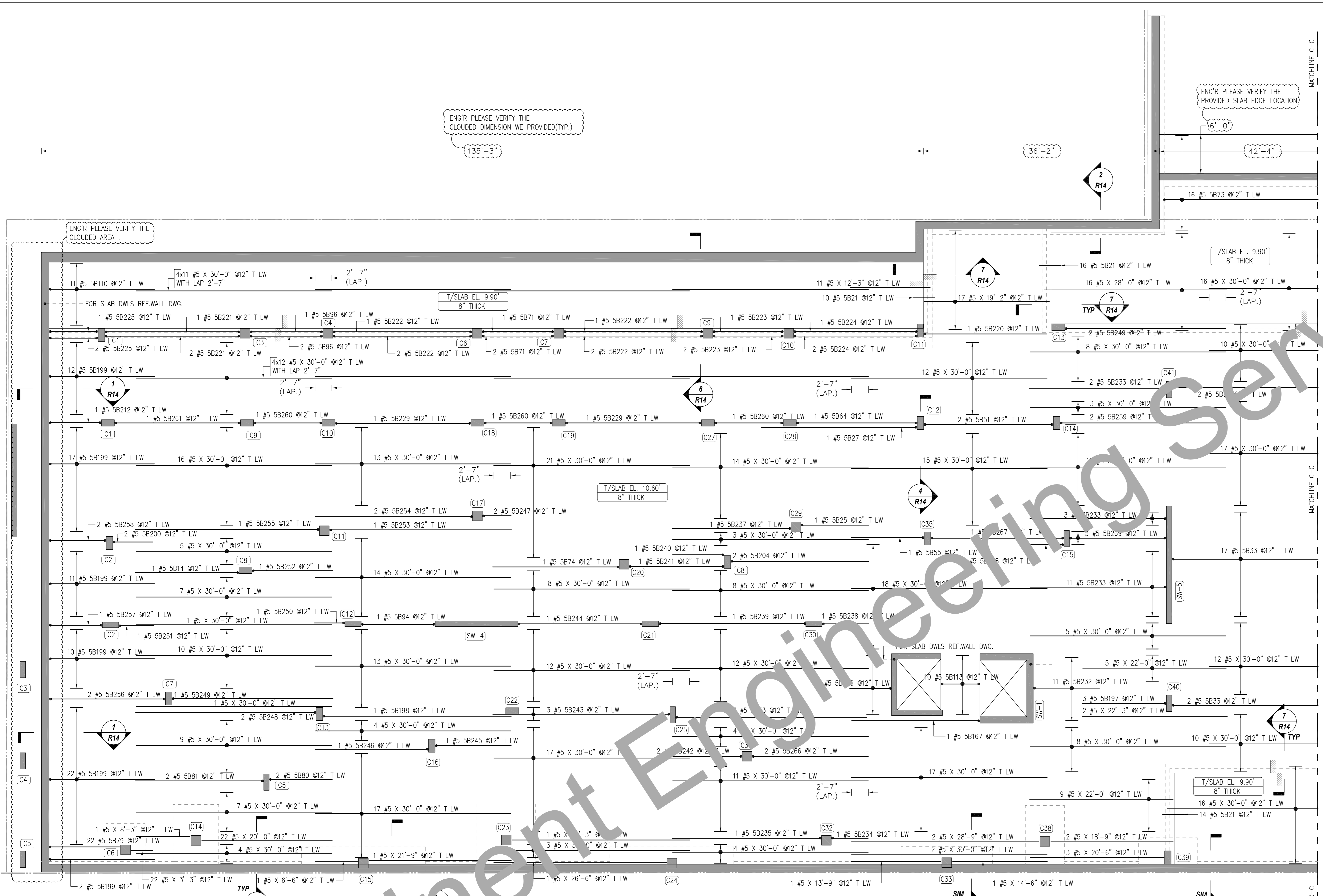

Rebar Number	ID	Qty	Size	Total Length	Top	X	Y	Z	W	V	U	V	W	V	W
SB14	#5	16	5	16'-7"	2	0'-10"	15'-9"								
SB21	#5	5	5	5'-6"	3	0'-10"	2'-7"								
SB25	#5	11	5	11'-1"	2	0'-10"	10'-5"								
SB27	#5	24	5	24'-7"	2	0'-10"	25'-9"								
SB33	#5	24	5	30'-0"	2	0'-10"	29'-7"								
SB41	#5	2	5	21'-2"	2	0'-10"	18'-5"								
SB45	#5	11	5	11'-10"	2	0'-10"	10'-5"								
SB46	#5	1	5	19'-11"	2	0'-10"	18'-5"								
SB71	#5	3	5	12'-4"	2	0'-10"	10'-5"								
SB73	#5	16	5	25'-11"	2	0'-10"	24'-4"								
SB74	#5	1	5	11'-11"	2	0'-10"	10'-5"								
SB78	#5	22	5	11'-4"	2	0'-10"	10'-5"								
SB80	#5	2	5	10'-4"	2	0'-10"	10'-5"								
SB81	#5	1	5	19'-4"	2	0'-10"	19'-4"								
SB82	#5	1	5	8'-1"	2	0'-10"	11'-0"								
SB83	#5	3	5	18'-4"	2	0'-10"	18'-4"								
SB84	#5	10	5	6'-8"	17	0'-4"	5'-8"								
SB85	#5	1	5	20'-0"	17	0'-4"	19'-6"								
SB19	#5	1	5	13'-7"	2	0'-10"	12'-9"								
SB88	#5	1	5	29'-7"	2	0'-10"	28'-9"								
SB89	#5	24	5	15'-10"	2	0'-10"	15'-0"								
SB93	#5	2	5	6'-10"	2	0'-10"	6'-0"								
SB94	#5	2	5	21'-10"	2	0'-10"	21'-0"								
SB95	#5	1	5	9'-4"	2	0'-10"	7'-8"								
SB97	#5	1	5	19'-7"	2	0'-10"	18'-9"								
SB98	#5	3	5	22'-1"	2	0'-10"	20'-5"								
SB99	#5	4	5	22'-5"	2	0'-10"	21'-9"								
SB23	#5	3	5	12'-2"	2	0'-10"	10'-4"								
SB24	#5	3	5	20'-4"	2	0'-10"	18'-8"								
SB25	#5	3	5	8'-10"	2	0'-10"	7'-2"								
SB29	#5	2	5	22'-2"	2	0'-10"	20'-4"								
SB32	#5	4	5	22'-5"	2	0'-10"	21'-9"								
SB33	#5	16	5	21'-7"	2	0'-10"	20'-9"								
SB34	#5	1	5	6'-4"	2	0'-10"	5'-8"								
SB35	#5	1	5	23'-7"	2	0'-10"	22'-9"								
SB36	#5	10	5	7'-1"	2	0'-10"	6'-5"								
SB37	#5	1	5	18'-10"	2	0'-10"	18'-0"								
SB38	#5	1	5	7'-10"	2	0'-10"	7'-0"								
SB39	#5	1	5	23'-11"	2	0'-10"	22'-3"								
SB40	#5	1	5	8'-7"	2	0'-10"	7'-9"								
SB41	#5	1	5	15'-11"	2	0'-10"	14'-3"								
SB42	#5	2	5	11'-4"	2	0'-10"	10'-6"								
SB43	#5	3	5	27'-10"	2	0'-10"	27'-0"								
SB44	#5	1	5	20'-5"	2	0'-10"	18'-9"								
SB45	#5	1	5	12'-4"	2	0'-10"	11'-4"								
SB46	#5	1	5	18'-1"	2	0'-10"	17'-3"								
SB47	#5	2	5	5'-1"	2	0'-10"	4'-3"								
SB48	#5	2	5	28'-4"	2	0'-10"	27'-6"								
SB49	#5	3	5	25'-4"	2	0'-10"	24'-6"								
SB50	#5	5	5	5'-4"	2	0'-10"	4'-4"								
SB51	#5	1	5	6'-1"	2	0'-10"	5'-3"								
SB52	#5	1	5	13'-1"	2	0'-10"	12'-3"								
SB53	#5	1	5	28'-7"	2	0'-10"	27'-9"								
SB54	#5	2	5	24'-10"	2	0'-10"	24'-0"								
SB55	#5	1	5	28'-10"	2	0'-10"	28'-0"								
SB56	#5	2	5	19'-7"	2	0'-10"	17'-4"								
SB57	#5	1	5	9'-6"	2	0'-10"	7'-10"								
SB58	#5	2	5	10'-1"	2	0'-10"	8'-5"								
SB59	#5	2	5	26'-4"	2	0'-10"	25'-6"								
SB60	#5	3	5	15'-10"	2	0'-10"	15'-0"								
SB61	#5	1	5	20'-8"	2	0'-10"	19'-0"								
SB67	#5	1	5	21'-9"	2	0'-10"	20'-1"								
SB68	#5	1	5	6'-0"	2	0'-10"	5'-2"								
SB69	#5	3	5	16'-2"	2	0'-10"	14'-4"								

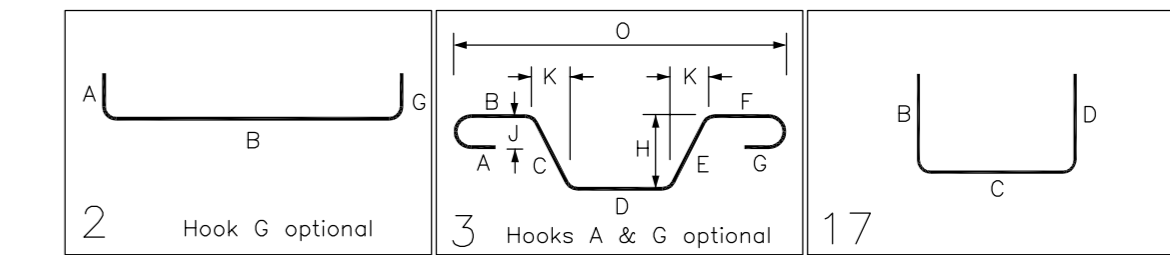

**LEVEL -1 SLAB ON GRADE TOP LONG WAY BARS**

SCALE: 1/8"=1'-0"  
SDR: FO-001.00, FO-101.00 & FO-102.00, FO-201.00 & FO-202.00,

LAP NOTES:  
LAP VALUES AS PER SHEET NO. FO-001.00

**FOR APPROVAL**

- NOTES:**
- TOP OF SOG SHORT WAY REFER PLAN
  - COVER DETAILS:  
FOR SOG: BOT = 3/4", TOP = 3/4" & SIDES = 2"
  - STOCK LENGTH USED IS 30'-0"

CLASS B LAP 4000 PSI FOR SLAB	SIZE	TOP	OTHERS
#3	24"	19"	
#4	32"	25"	
#5	40"	31"	
#6	48"	37"	
#7	70"	54"	
#8	80"	62"	
#9	91"	70"	
#10	102"	79"	
#11	113"	87"	

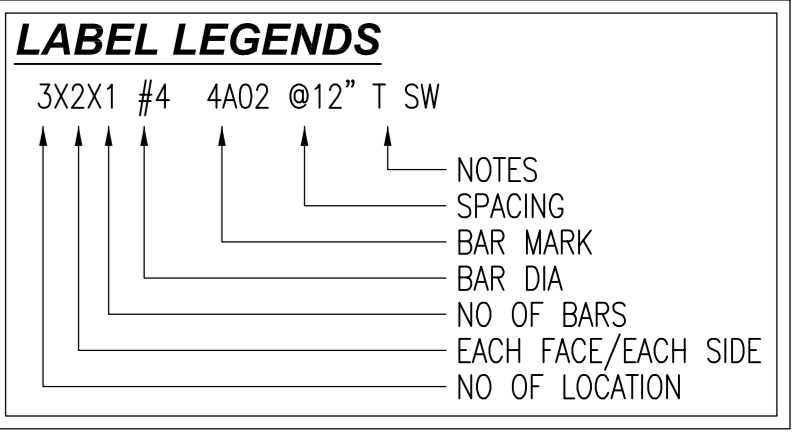

- REFERENCE DRAWINGS**
- FOR REBAR DETAIL OF LEVEL-1 SLAB ON GRADE TOP LONG WAY REFER DRAWING #R06
  - FOR REBAR DETAIL OF LEVEL-1 SLAB ON GRADE TOP LONG WAY REFER DRAWING #R07
  - FOR REBAR DETAIL OF LEVEL-1 SLAB ON GRADE TOP SHORT WAY REFER DRAWING #R08
  - FOR REBAR DETAIL OF LEVEL-1 SLAB ON GRADE TOP SHORT WAY REFER DRAWING #R09
  - FOR REBAR DETAIL OF LEVEL-1 SLAB ON GRADE BOTTOM LONG WAY REFER DRAWING #R11
  - FOR REBAR DETAIL OF LEVEL-1 SLAB ON GRADE BOTTOM SHORT WAY REFER DRAWING #R12
  - FOR REBAR DETAIL OF LEVEL-1 SLAB ON GRADE BOTTOM SHORT WAY REFER DRAWING #R13
  - FOR REBAR DETAIL OF LEVEL-1 SLAB ON GRADE SECTIONS REFER DRAWING #R14

REINFORCING STEEL PLACING DRAWING ONLY. USE IN CONJUNCTION WITH CONTRACT DRAWINGS & SPECIFICATIONS. ELEVATIONS & DIMENSIONS SHOWN ON DRAWING ARE FOR DETAILING PURPOSES ONLY AND SHOULD NOT BE USED FOR CONSTRUCTION UNLESS VERIFIED BY ENGINEER OR CONTRACTOR.

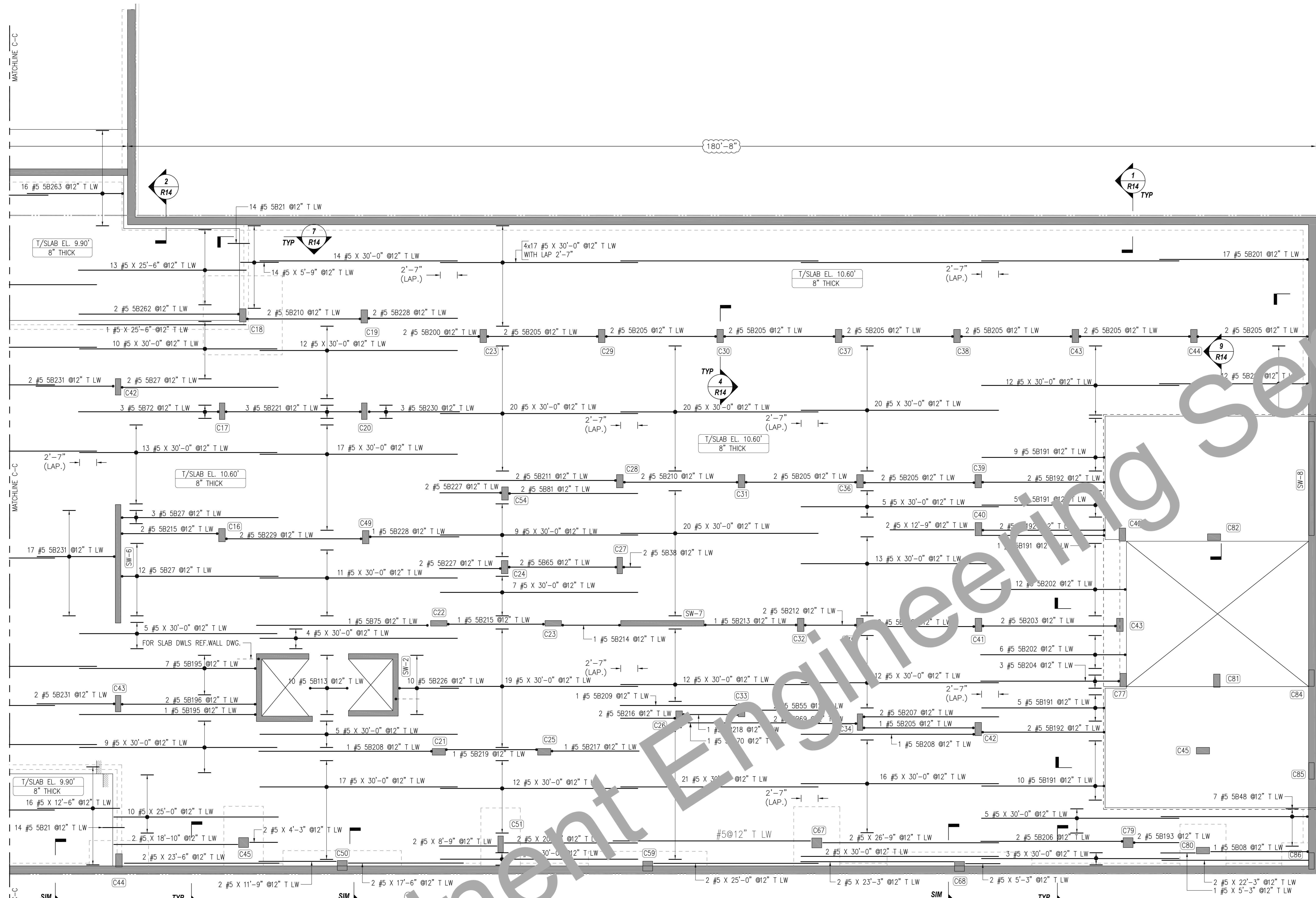

Release Number: R11

Bar Mark	Qty	Size	Total Length	Type	X	Y	Z	Y'	Y''	Y'''	Y''''	Y'''''	Y''''''	Y'''''''
5808	1	#5	15'-7"	2	0'-10"									
5809	2	#5	3'-6"	3	2'-7"									
5827	17	#5	24'-7"	2	0'-10"	23'-9"							0'-8"	0'-8"
5838	2	#5	3'-5"	2	0'-10"	2'-7"								5'-5"
5848	7	#5	23'-1"	2	0'-10"	22'-3"								
5855	2	#5	11'-10"	2	0'-10"									
5865	2	#5	17'-11"	2	0'-10"								0'-10"	
5869	2	#5	9'-4"	2	0'-10"	8'-6"								
5872	3	#5	22'-1"	2	0'-10"									
5875	1	#5	26'-10"	2	0'-10"									
5881	2	#5	11'-10"	2	0'-10"									
5813	10	#5	15'-11"	17	0'-10"	14'-6"							0'-6"	
5819	17	#5	15'-5"	2	0'-10"	14'-11"								
58192	1	#5	18'-11"	2	0'-10"								0'-10"	
58197	2	#5	17'-11"	2	0'-10"									
5819	8	#5	27'-2"	2	0'-10"	26'-9"								
5819	2	#5	17'-11"	2	0'-10"	20'-5"							0'-10"	
58200	2	#5	15'-4"	2	0'-10"	22'-6"								
58201	2	#5	15'-4"	2	0'-10"	22'-6"								
58202	2	#5	22'-10"	2	0'-10"	22'-0"								
5820	2	#5	21'-10"	2	0'-10"	20'-2"							0'-10"	
5820	3	#5	21'-10"	2	0'-10"	21'-0"								
58209	2	#5	18'-4"	2	0'-10"	16'-8"							0'-10"	
58206	2	#5	22'-4"	2	0'-10"	21'-6"								
58207	2	#5	21'-4"	2	0'-10"	20'-6"								
58208	2	#5	27'-1"	2	0'-10"	26'-3"								
58209	1	#5	18'-7"	2	0'-10"	17'-9"								
58210	4	#5	18'-10"	2	0'-10"	17'-2"							0'-10"	
58211	2	#5	27'-7"	2	0'-10"	26'-9"								
58212	2	#5	24'-4"	2	0'-10"	2'-6"								0'-10"
58213	1	#5	15'-5"	2	0'-10"	13'-10"								0'-10"
58214	1	#5	10'-4"	2	0'-10"	8'-6"								0'-10"
58215	3	#5	16'-3"	2	0'-10"	14'-6"								0'-10"
58216	2	#5	9'-1"	2	0'-10"	8'-3"								
58217	1	#5	14'-4"	2	0'-10"	13'-5"								
58218	1	#5	9'-10"	2	0'-10"	8'-2"								0'-10"
58219	1	#5	15'-5"	2	0'-10"	13'-9"								0'-10"
58221	3	#5	22'-1"	2	0'-10"	20'-5"								0'-10"
58226	10	#5	9'-6"	17	0'-6"	9'-0"								
58227	4	#5	10'-1"	2	0'-10"	9'-3"								
58228	3	#5	14'-4"	2	0'-10"	13'-6"								
58229	2	#5	22'-2"	2	0'-10"	20'-6"								0'-10"
58230	3	#5	14'-7"	2	0'-10"	13'-9"								
58231	2	#5	12'-7"	2	0'-10"	11'-9"								
58242	2	#5	24'-7"	17	0'-4"	24'-5"								
58243	16	#5	14'-10"	17	0'-4"	14'-8"								
58244	1	#5	5'-6"	17	0'-6"	5'-0"								
58245	1	#5	17'-0"	17	0'-6"	16'-6"								
58246	2	#5	18'-6"	2	0'-10"	17'-8"								
58270	1	#5	21'-6"	2	0'-10"	20'-8"								

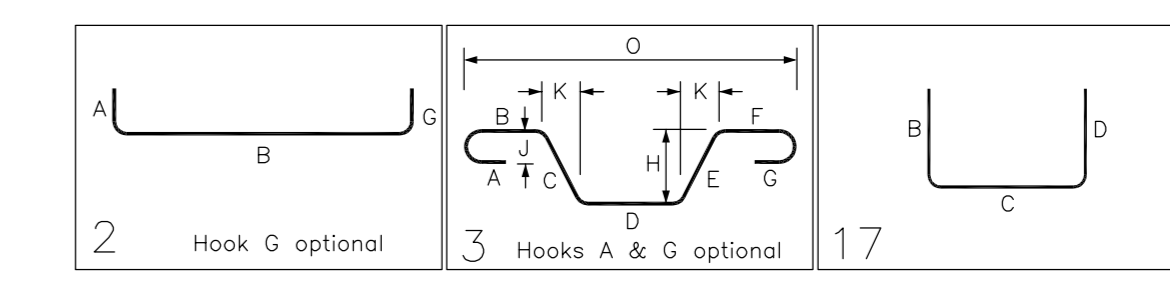

**LEVEL -1 SLAB ON GRADE TOP LONG WAY BARS**

SCALE: 1/8=1'-0"  
SDR: FO-001.00, FO-101.00 & FO-102.00, FO-201.00 & FO-202.00,

**FOR APPROVAL**

**LAP NOTES:**  
LAP VALUES AS PER SHEET NO. FO-001.00

**CLASS B LAP 4000 PSI FOR SLAB**

SIZE	TOP	OTHERS
#3	24"	19"
#4	32"	25"
#5	40"	31"
#6	48"	37"
#7	70"	54"
#8	80"	62"
#9	91"	70"
#10	102"	79"
#11	113"	87"

**NOTES:**  
1. TOP OF SOG LEVEL REFER PLAN  
2. COVER DETAILS:  
FOR SOG: BOT = 3/4", TOP = 3/4" & SIDES = 2"  
3. STOCK LENGTH USED IS 30'-0"

**LABEL LEGENDS**

3x2x1 #4 4x2 @12" T SW

NOTES  
SPACING  
BAR MARK  
BAR DIA  
NO OF BARS  
EACH FACE/EACH SIDE  
NO OF LOCATION

**REFERENCE DRAWINGS**

FOR REBAR DETAIL OF LEVEL-1 SLAB ON GRADE TOP LONG WAY REFER DRAWING #R06  
FOR REBAR DETAIL OF LEVEL-1 SLAB ON GRADE TOP LONG WAY REFER DRAWING #R07  
FOR REBAR DETAIL OF LEVEL-1 SLAB ON GRADE TOP SHORT WAY REFER DRAWING #R08  
FOR REBAR DETAIL OF LEVEL-1 SLAB ON GRADE TOP SHORT WAY REFER DRAWING #R09  
FOR REBAR DETAIL OF LEVEL-1 SLAB ON GRADE BOTTOM LONG WAY REFER DRAWING #R10  
FOR REBAR DETAIL OF LEVEL-1 SLAB ON GRADE BOTTOM SHORT WAY REFER DRAWING #R11  
FOR REBAR DETAIL OF LEVEL-1 SLAB ON GRADE BOTTOM SHORT WAY REFER DRAWING #R12  
FOR REBAR DETAIL OF LEVEL-1 SLAB ON GRADE SECTIONS REFER DRAWING #R14

REINFORCING STEEL PLACING DRAWING ONLY USE IN CONJUNCTION WITH CONTRACT DRAWINGS & SPECIFICATIONS. ELEVATIONS & DIMENSIONS SHOWN ON DRAWINGS ARE FOR DETAILING PURPOSES ONLY AND SHOULD NOT BE USED FOR CONSTRUCTION UNLESS VERIFIED BY ENGINEER OR CONTRACTOR.

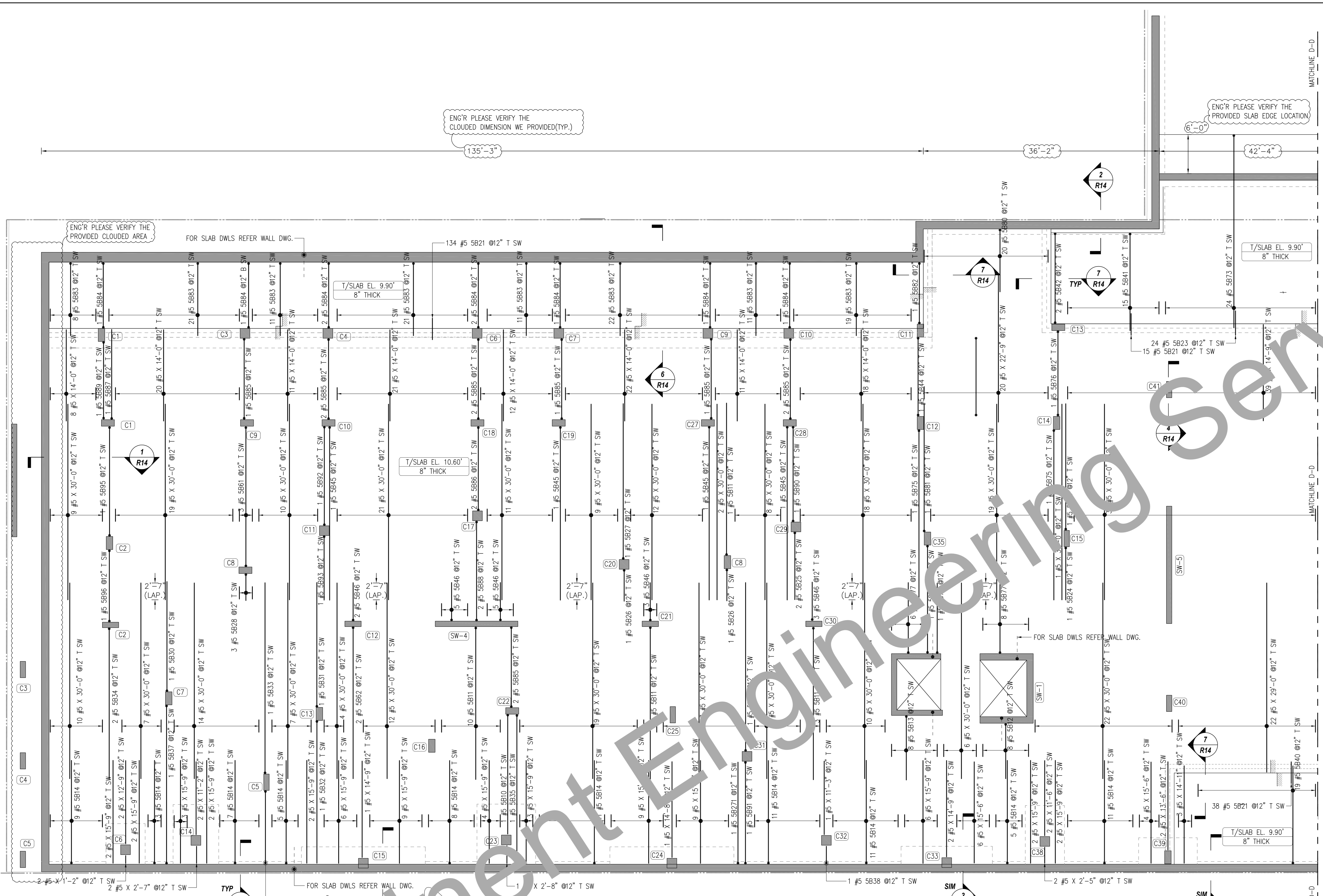

**LEVEL -1 SLAB ON GRADE TOP SHORT WAY BARS**

SCALE: 1/8"=1'-0"  
SDR: FO-001.00, FO-101.00 & FO-102.00, FO-201.00 & FO-202.00,

Release Number	R12	Bar No.	Qty	Size	Total Length	Type	X	Y	Z	BENDING DETAILS
		5810	1	#5	12'-11"	2	0'-10"			
		5811	17	#5	24'-11"	2	0'-10"	23'-3"		
		5812	8	#5	8'-10"	17		0'-6"	8'-4"	
		5813	8	#5	10'-3"	17		0'-6"	9'-9"	
		5814	76	#5	16'-7"	2	0'-10"			
		5815	5	#5	16'-7"	2	0'-10"			
		5816	187	#5	3'-6"	3	2'-7"	0'-11"	0'-8"	0'-5"
		5817	24	#5	3'-11"	3	3		0'-8"	0'-5"
		5818	1	#5						
		5819	2	#5						
		5820	2	#5						
		5821	1	#5						
		5822	1	#5						
		5823	24	#5	22'-9"	2	0'-10"			
		5824	15	#5	22'-9"	2	0'-10"			
		5825	2	#5						
		5826	2	#5						
		5827	1	#5						
		5828	1	#5						
		5829	1	#5						
		5830	1	#5						
		5831	1	#5						
		5832	1	#5						
		5833	1	#5						
		5834	1	#5						
		5835	1	#5						
		5836	1	#5						
		5837	1	#5						
		5838	1	#5						
		5839	1	#5						
		5840	1	#5						
		5841	1	#5						
		5842	2	#5						
		5843	1	#5						
		5844	1	#5						
		5845	4	#5						
		5846	18	#5						
		5847	3	#5						
		5848	2	#5						
		5849	1	#5						
		5850	24	#5						
		5851	1	#5						
		5852	1	#5						
		5853	1	#5						
		5854	1	#5						
		5855	1	#5						
		5856	1	#5						
		5857	1	#5						
		5858	1	#5						
		5859	1	#5						
		5860	1	#5						
		5861	1	#5						
		5862	1	#5						
		5863	1	#5						
		5864	1	#5						
		5865	1	#5						
		5866	1	#5						
		5867	1	#5						
		5868	1	#5						
		5869	1	#5						
		5870	1	#5						
		5871	1	#5						

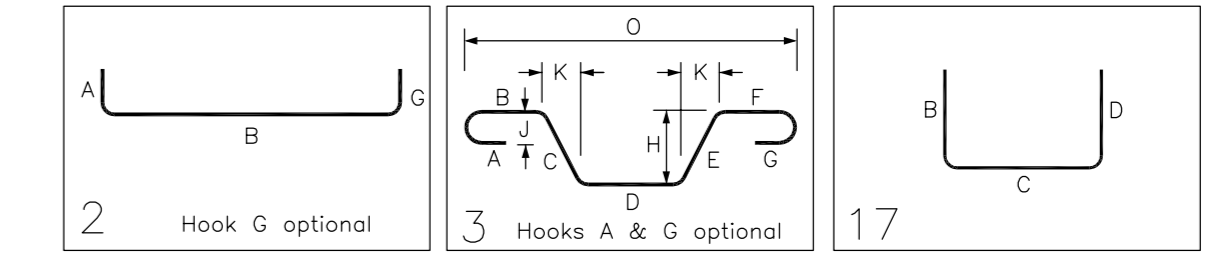

LAP NOTES:  
LAP VALUES AS PER SHEET NO. FO-001.00

CLASS B LAP 4000 PSI FOR SLAB

SIZE	TOP	OTHERS
#3	24"	19"
#4	32"	25"
#5	40"	31"
#6	48"	37"
#7	70"	54"
#8	80"	62"
#9	91"	70"
#10	102"	79"
#11	113"	87"

FOR APPROVAL

NOTES:  
1. TOP OF SOG LEVEL REFER PLAN  
2. COVER DETAILS:  
FOR SOG: BOT = 3/4", TOP = 3/4" & SIDES = 2"  
3. STOCK LENGTH USED IS 30'-0"

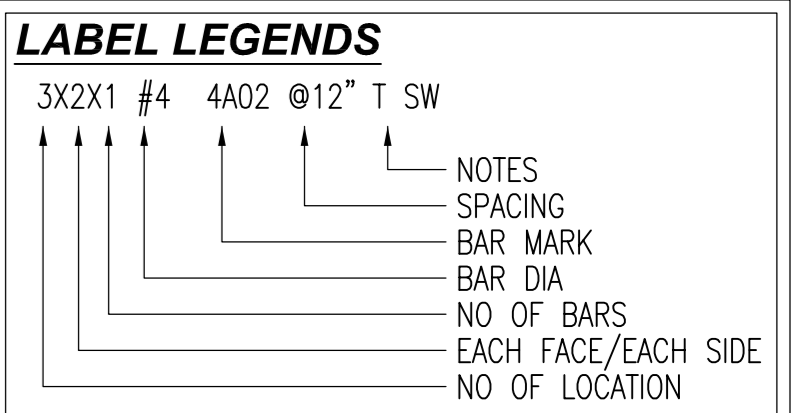

REFERENCE DRAWINGS

FOR REBAR DETAIL OF LEVEL-1 SLAB ON GRADE TOP LONG WAY REFER DRAWING #R06  
FOR REBAR DETAIL OF LEVEL-1 SLAB ON GRADE TOP LONG WAY REFER DRAWING #R07  
FOR REBAR DETAIL OF LEVEL-1 SLAB ON GRADE TOP SHORT WAY REFER DRAWING #R08  
FOR REBAR DETAIL OF LEVEL-1 SLAB ON GRADE TOP SHORT WAY REFER DRAWING #R09  
FOR REBAR DETAIL OF LEVEL-1 SLAB ON GRADE BOTTOM LONG WAY REFER DRAWING #R10  
FOR REBAR DETAIL OF LEVEL-1 SLAB ON GRADE BOTTOM LONG WAY REFER DRAWING #R11  
FOR REBAR DETAIL OF LEVEL-1 SLAB ON GRADE BOTTOM SHORT WAY REFER DRAWING #R12  
FOR REBAR DETAIL OF LEVEL-1 SLAB ON GRADE SECTIONS REFER DRAWING #R14

REINFORCING STEEL PLACING DRAWING ONLY. USE IN CONJUNCTION WITH CONTRACT DRAWINGS & SPECIFICATIONS. ELEVATIONS & DIMENSIONS SHOWN ON DRAWING ARE FOR DETAILING PURPOSES ONLY AND SHOULD NOT BE USED FOR CONSTRUCTION UNLESS VERIFIED BY ENGINEER OR CONTRACTOR.

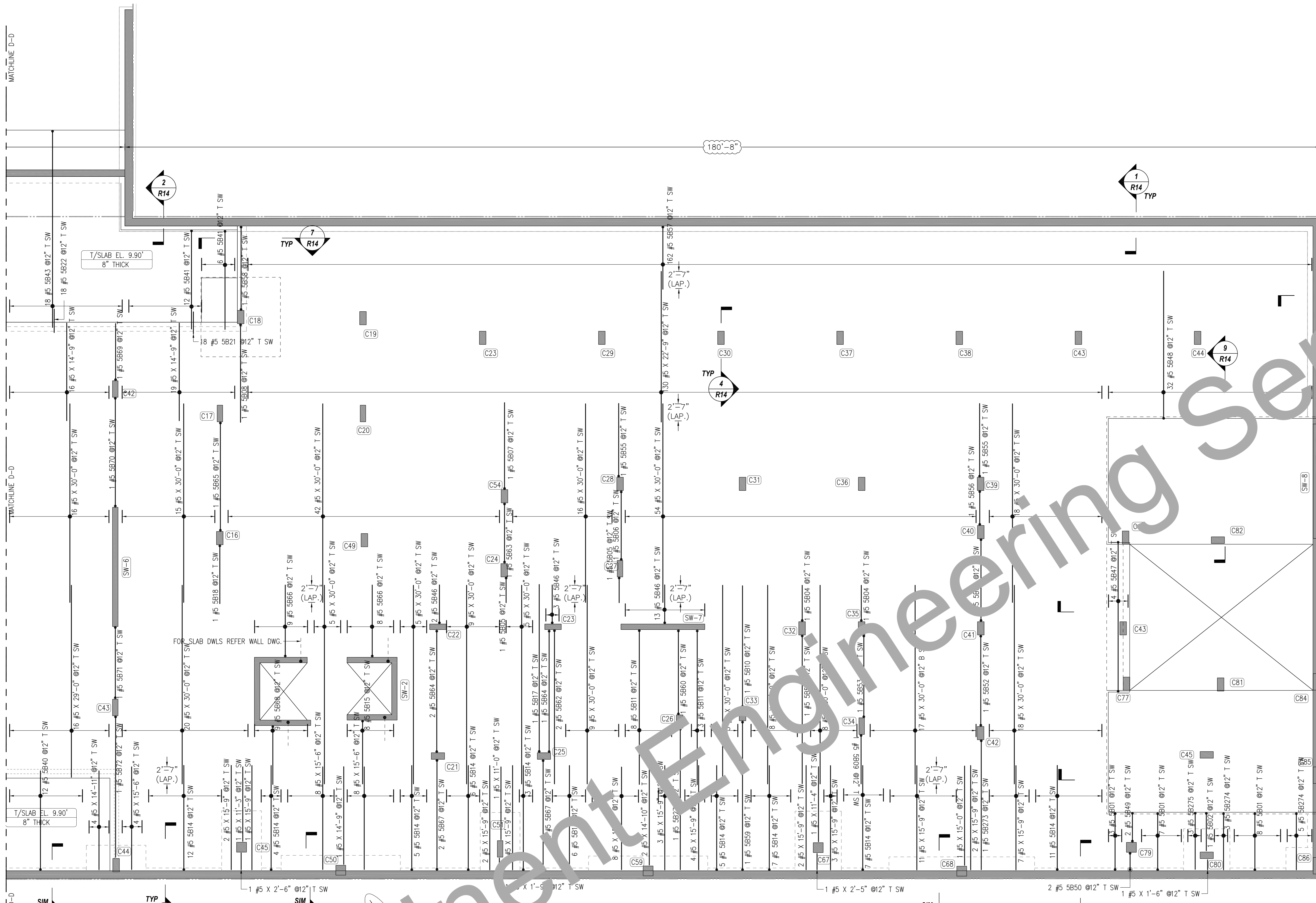

Release Number: R13

Bar Mark	Qty	Size	Total Length	Type	W'	W''	W'''	W''''	W'''''	W''''''	W'''''''	W''''''''	W'''''''''	W''''''''''	W'''''''''
5801	18	#5	10'-2"	2											
5802	18	#5	10'-2"	2											
5804	2	#5	4'-7"	2											
5805	2	#5	4'-7"	2											
5806	1	#5	11'-6"	2											
5807	1	#5	11'-6"	2											
5808	1	#5	15'-7"	2											
5809	1	#5	15'-7"	2											
5810	1	#5	15'-7"	2											
5811	11	#5	24'-1"	2											
5812	61	#5	16'-7"	2											
5813	1	#5	16'-7"	2											
5814	8	#5	10'-0"	17											9'-6"
5817	1	#5	28'-1"	2											
5818	1	#5	9'-7"	2											
5821	18	#5	3'-6"	3											0'-8" N
5822	18	#5	3'-6"	3											0'-8" N
5840	12	#5	15'-3"	17											0'-4" N
5841	18	#5	15'-3"	17											0'-4" N
5843	18	#5	30'-0"	17											0'-4" N
5846	18	#5	6'-7"	2											5'-9"
5847	4	#5	24'-3"	2											0'-10"
5848	32	#5	23'-1"	2											0'-10"
5849	2	#5	5'-11"	2											0'-10"
5850	2	#5	4'-7"	2											0'-10"
5852	1	#5	15'-2"	2											0'-10"
5853	2	#5	15'-11"	2											0'-10"
5854	1	#5	23'-2"	2											22'-4"
5855	2	#5	11'-10"	2											11'-0"
5856	1	#5	4'-8"	2											5'-0"
5857	162	#5	10'-3"	2											0'-10"
5858	1	#5	13'-2"	17											12'-4"
5859	1	#5	24'-0"	2											0'-10"
5860	1	#5	14'-3"	2											0'-10"
5862	2	#5	24'-0"	2											0'-10"
5863	1	#5	10'-6"	2											0'-10"
5864	3	#5	19'-11"	2											0'-10"
5865	1	#5	17'-11"	2											0'-10"
5866	17	#5	11'-3"	17											10'-9"
5867	4	#5	18'-2"	2											0'-10"
5868	9	#5	9'-3"	17											8'-9"
5869	1	#5	9'-4"	2											0'-10"
5870	1	#5	18'-0"	2											0'-10"
5871	1	#5	12'-4"	2											0'-10"
5872	1	#5	22'-1"	2											21'-3"
5872	1	#5	22'-1"	2											21'-3"
5873	1	#5	20'-4"	2											19'-6"
5874	3	#5	9'-4"	2											8'-6"
5874	3	#5	9'-4"	2											8'-6"
5875	5	#5	9'-4"	2											8'-6"
5875	5	#5	9'-4"	2											8'-6"

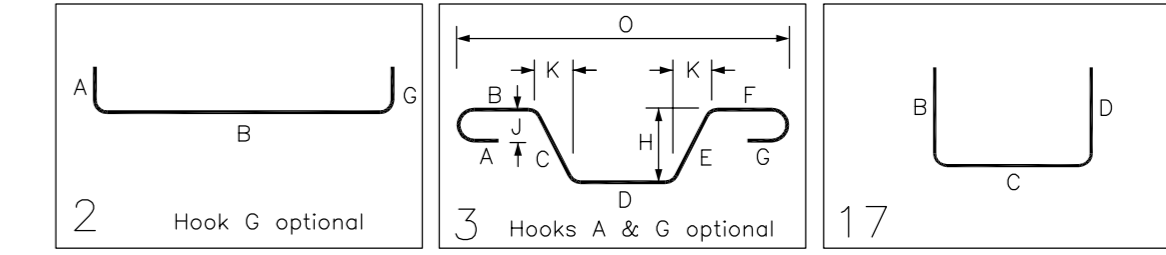

**LEVEL-1 SLAB ON GRADE TOP SHORT WAY BARS**

SCALE: 1/8"=1'-0"  
SDR: FO-001.00, FO-101.00 & FO-102.00, FO-201.00 & FO-202.00.

LAP NOTES:  
LAP VALUES AS PER SHEET NO. FO-001.00

CLASS B LAP 4000 PSI FOR SLAB

SIZE	TOP	OTHERS
#3	24"	19"
#4	32"	25"
#5	40"	31"
#6	48"	37"
#7	70"	54"
#8	80"	62"
#9	91"	70"
#10	102"	79"
#11	113"	87"

FOR APPROVAL

- NOTES:**
- TOP OF SOG LEVEL REFER PLAN
  - COVER DETAILS:  
FOR SOG: BOT = 3/4", TOP = 3/4" & SIDES = 2"
  - STOCK LENGTH USED IS 30'-0"

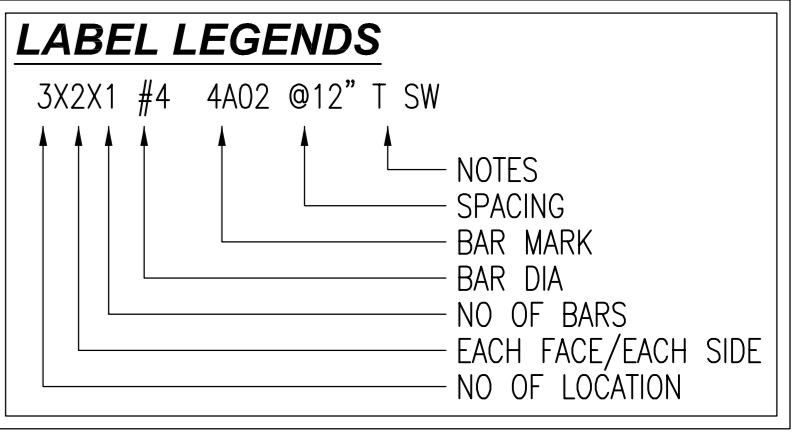

- REFERENCE DRAWINGS**
- FOR REBAR DETAIL OF LEVEL-1 SLAB ON GRADE TOP LONG WAY REFER DRAWING #R06
  - FOR REBAR DETAIL OF LEVEL-1 SLAB ON GRADE TOP LONG WAY REFER DRAWING #R07
  - FOR REBAR DETAIL OF LEVEL-1 SLAB ON GRADE TOP SHORT WAY REFER DRAWING #R08
  - FOR REBAR DETAIL OF LEVEL-1 SLAB ON GRADE TOP SHORT WAY REFER DRAWING #R09
  - FOR REBAR DETAIL OF LEVEL-1 SLAB ON GRADE BOTTOM LONG WAY REFER DRAWING #R10
  - FOR REBAR DETAIL OF LEVEL-1 SLAB ON GRADE BOTTOM LONG WAY REFER DRAWING #R11
  - FOR REBAR DETAIL OF LEVEL-1 SLAB ON GRADE BOTTOM SHORT WAY REFER DRAWING #R12
  - FOR REBAR DETAIL OF LEVEL-1 SLAB ON GRADE SECTIONS REFER DRAWING #R14

REINFORCING STEEL PLACING DRAWING ONLY. USE IN CONJUNCTION WITH CONTRACT DRAWINGS & SPECIFICATIONS. ELEVATIONS & DIMENSIONS SHOWN ON DRAWING ARE FOR DETAILING PURPOSES ONLY AND SHOULD NOT BE USED FOR CONSTRUCTION UNLESS VERIFIED BY ENGINEER OR CONTRACTOR.

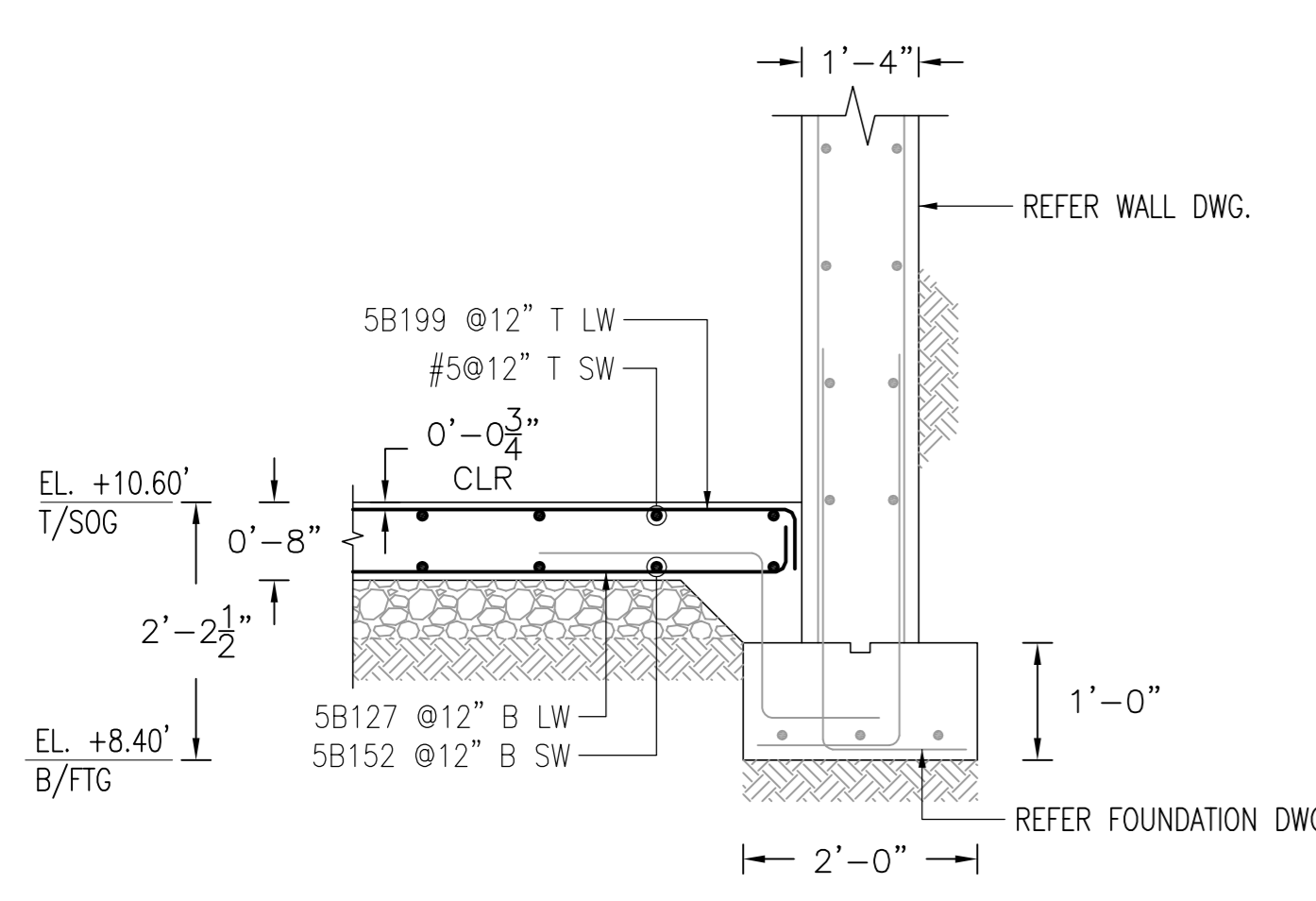

**1 SECTION**  
1/2"=1'-0"  
SDR: 1/FO-202.00

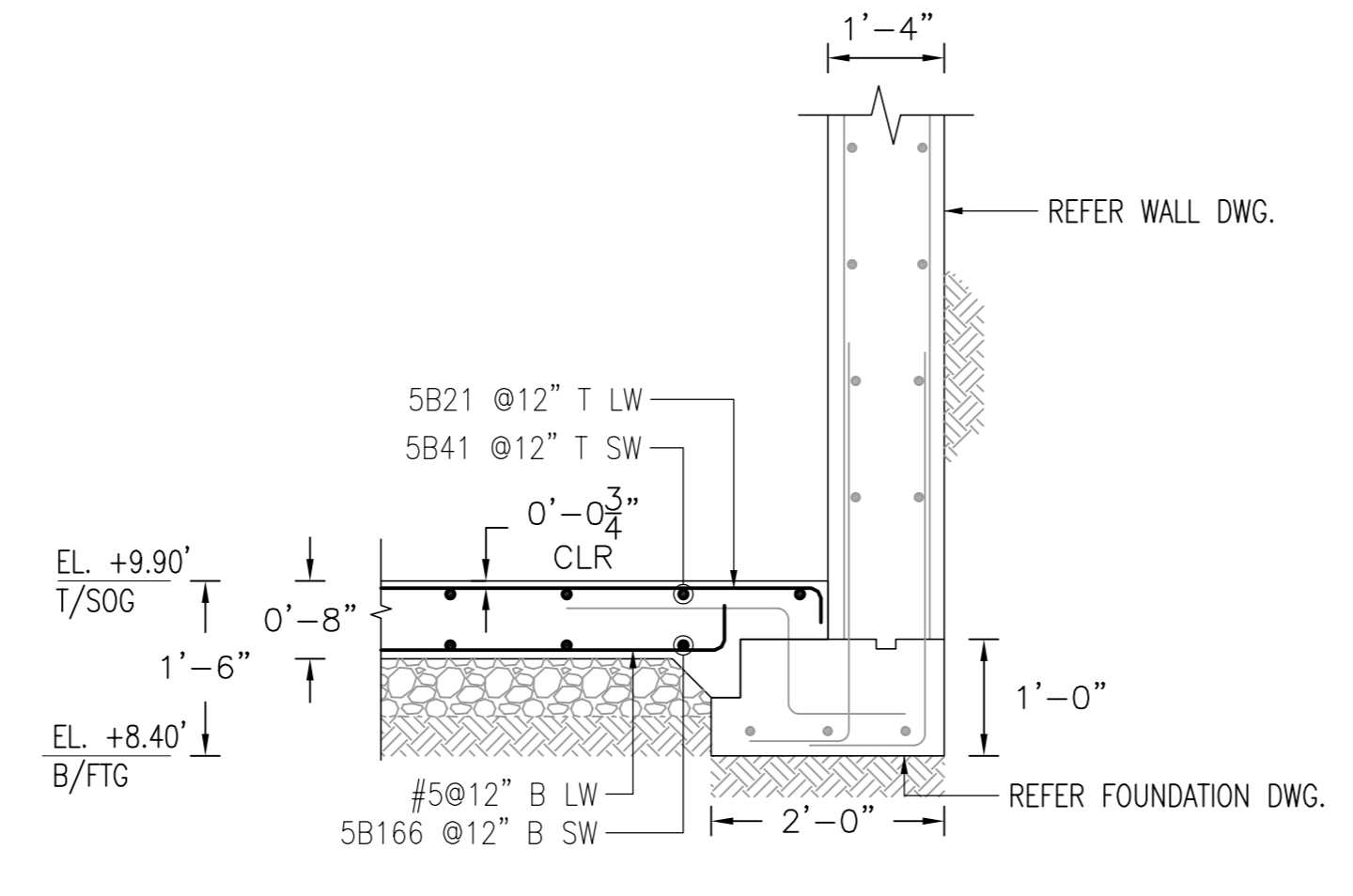

**2 SECTION**  
1/2"=1'-0"  
SDR: 8/FO-202.00

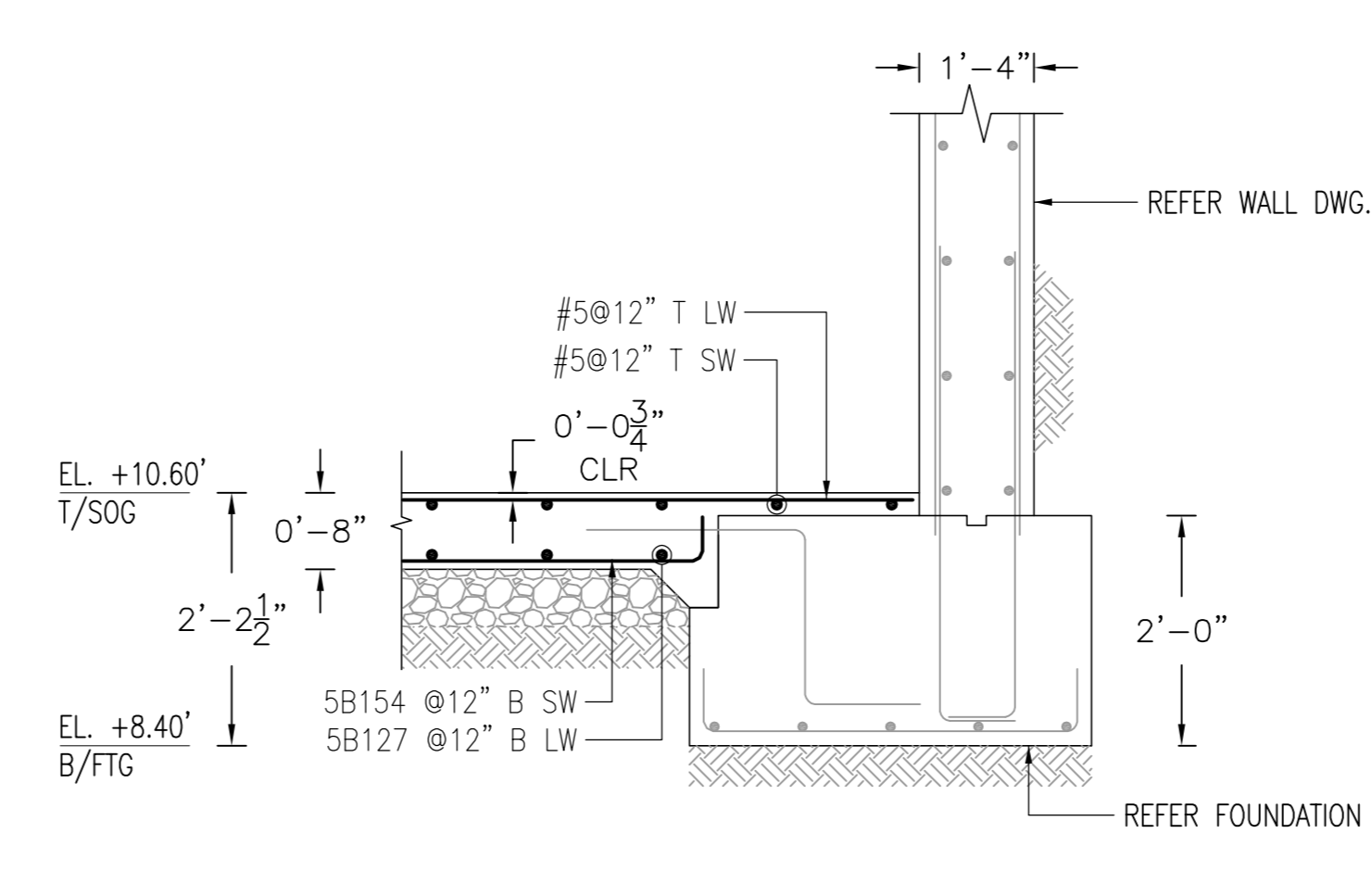

**3 SECTION**  
1/2"=1'-0"  
SDR: 1A/FO-202.00

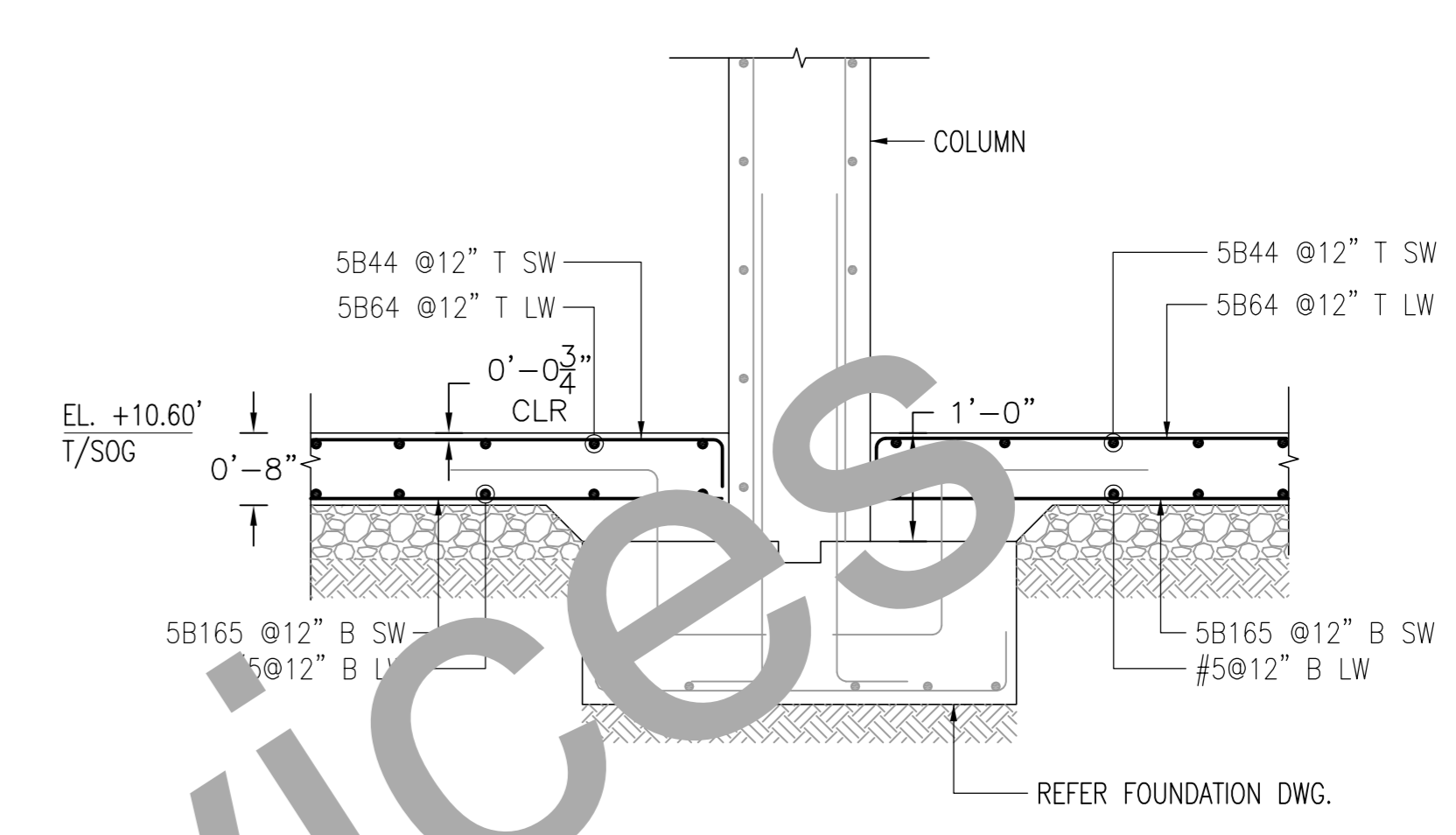

**4 SECTION**  
1/2"=1'-0"  
SDR: 1/FO-201.00

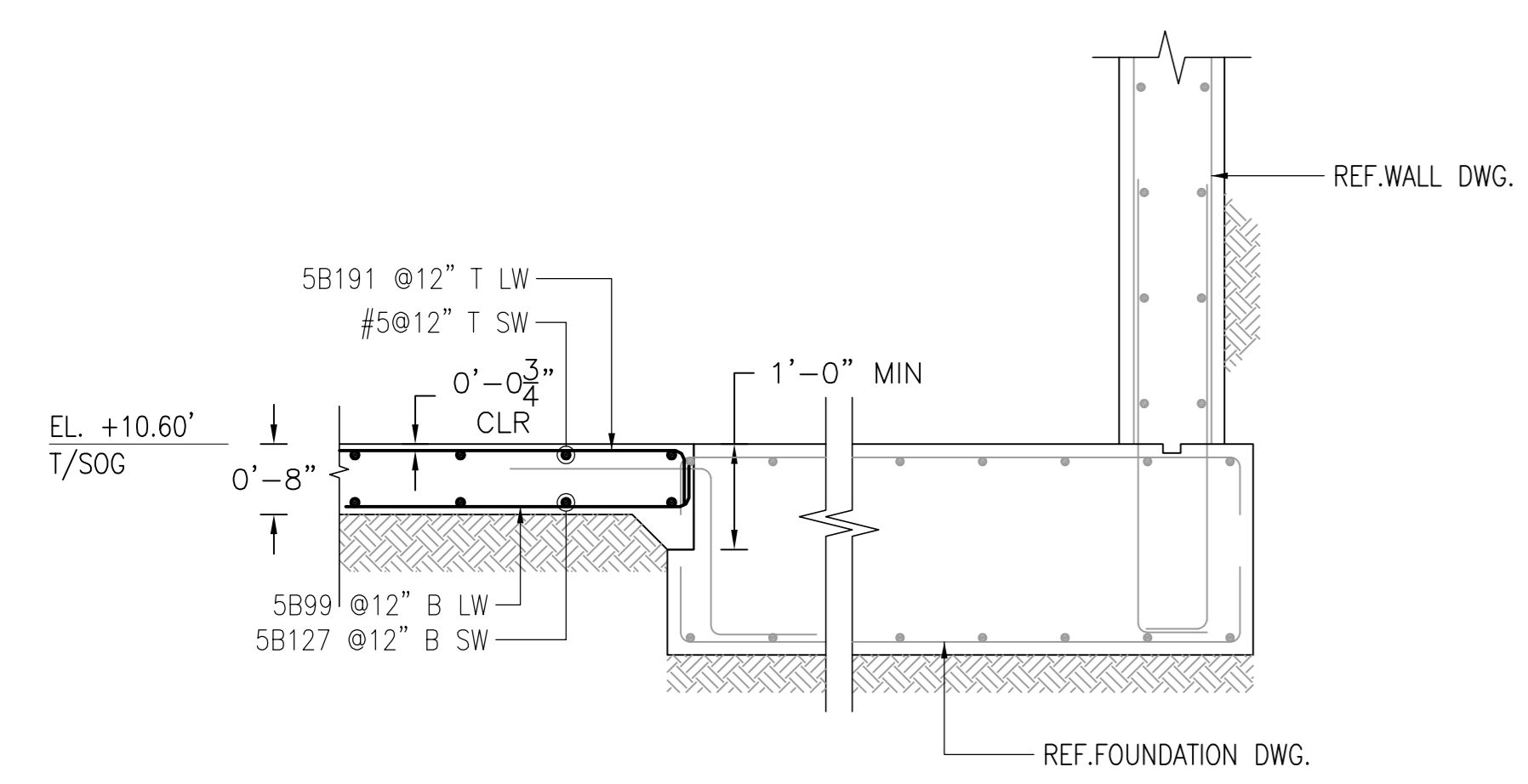

**5 SECTION**  
1/2"=1'-0"  
SDR: 3/FO-202.00

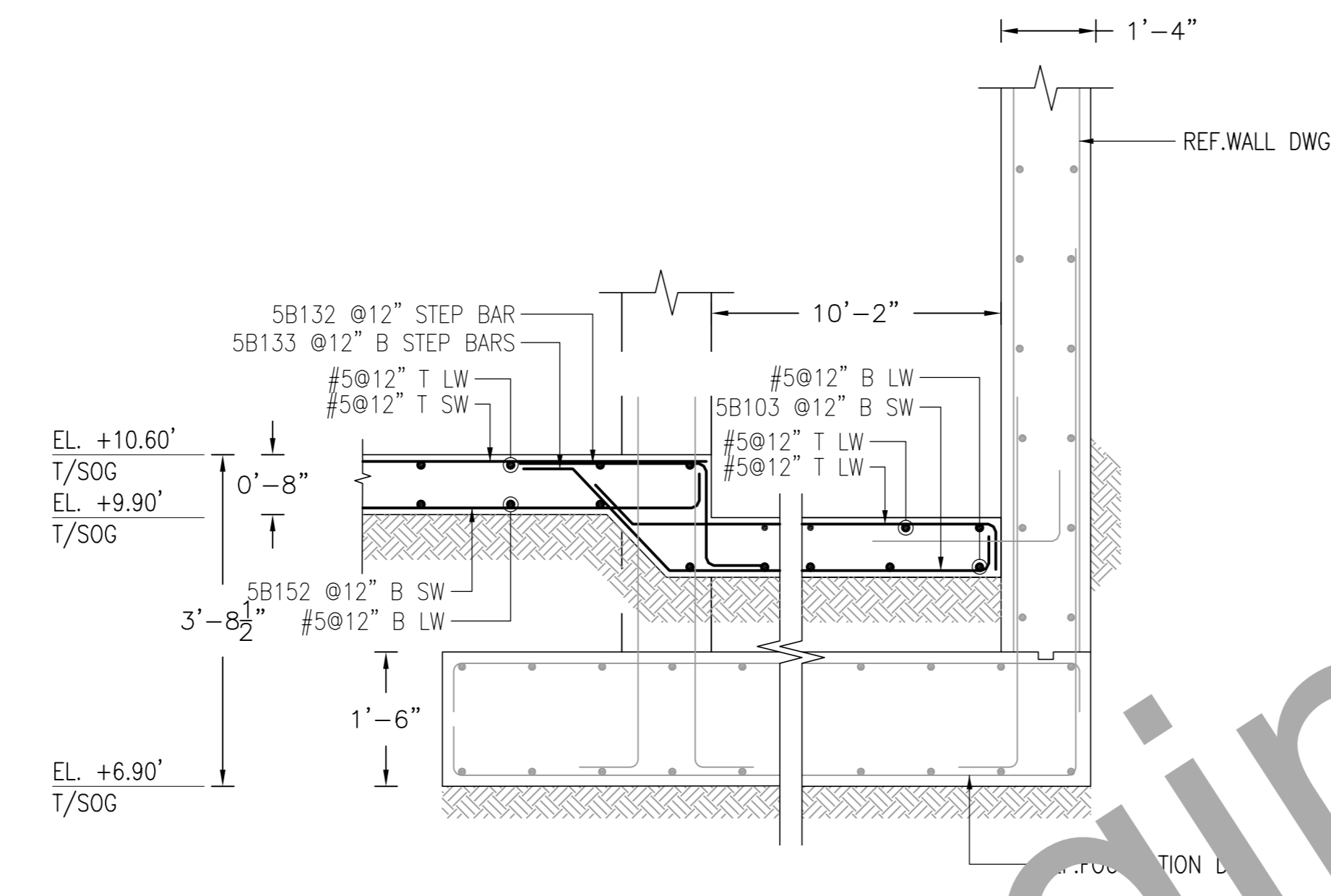

**6 SECTION**  
1/2"=1'-0"  
SDR: 9/FO-202.00

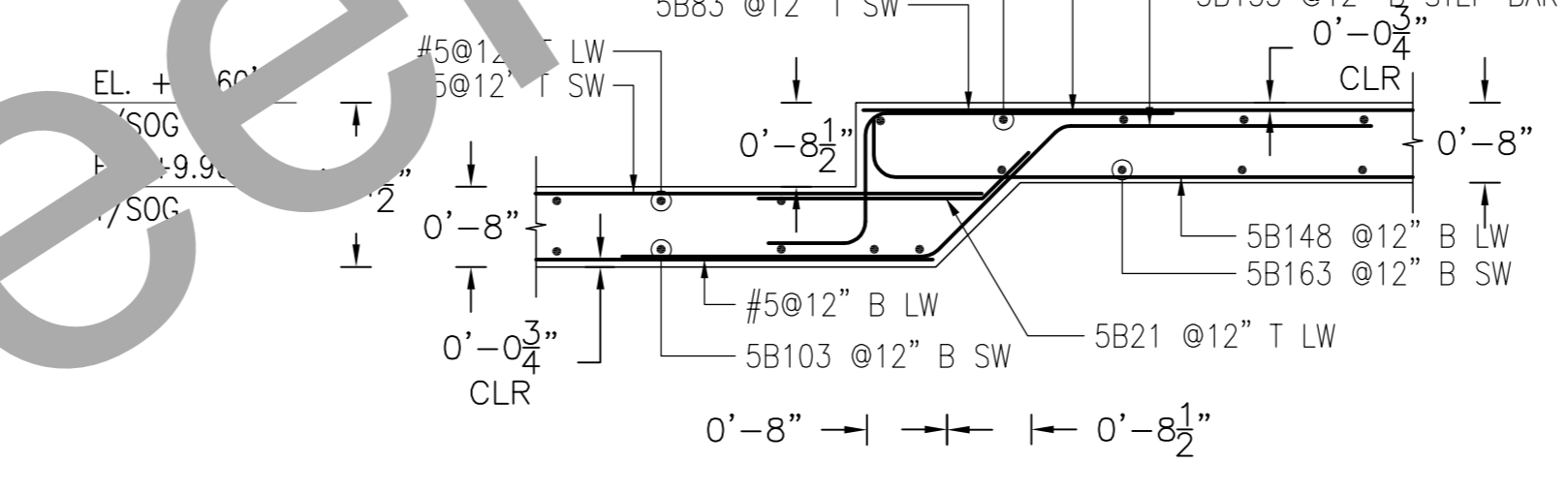

**7 SECTION**  
1/2"=1'-0"  
SDR: 4/FO-201.00

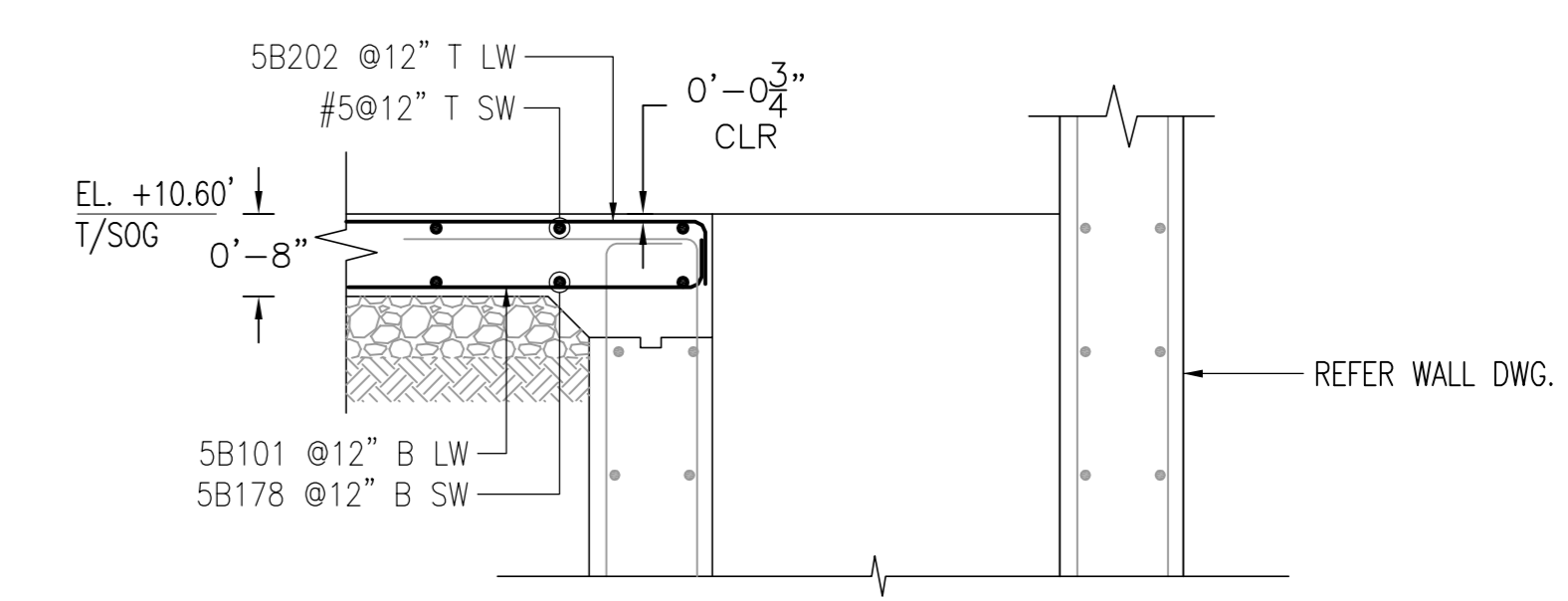

**8 SECTION**  
1/2"=1'-0"  
SDR: 4/FO-202.00

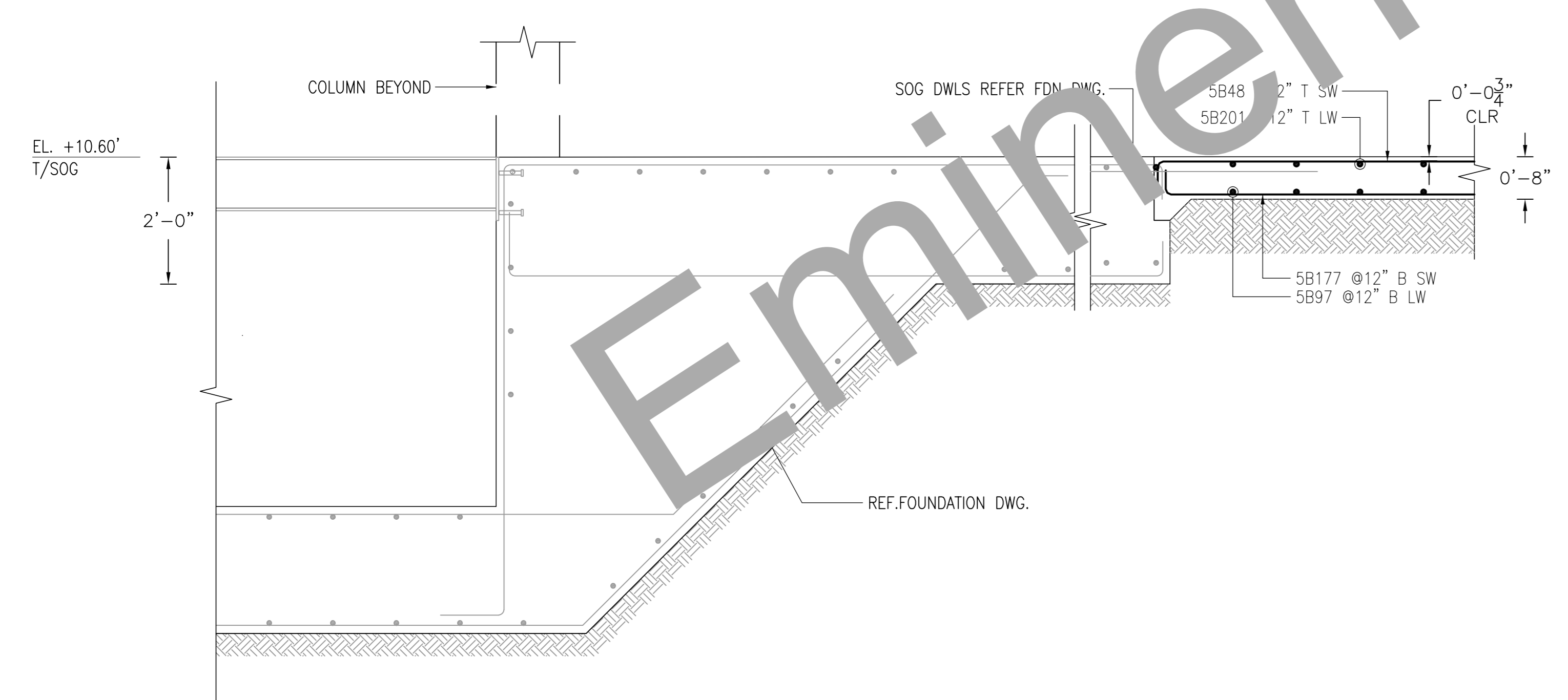

**9 SECTION**  
1/2"=1'-0"  
SDR: 5/FO-202.00

LAP NOTES:  
LAP VALUES AS PER SHEET NO. FO-001.00

CLASS B LAP 4000 PSI FOR SLAB		
SIZE	TOP	OTHERS
#3	24"	19"
#4	32"	25"
#5	40"	31"
#6	48"	37"
#7	70"	54"
#8	80"	62"
#9	91"	70"
#10	102"	79"
#11	113"	87"

FOR APPROVAL

**NOTES:**  
1. TOP OF SOG LEVEL REFER PLAN  
2. COVER DETAILS:  
FOR SOG: BOT = 3/4", TOP = 3/4" & SIDES = 2"  
3. STOCK LENGTH USED IS 30'-0"

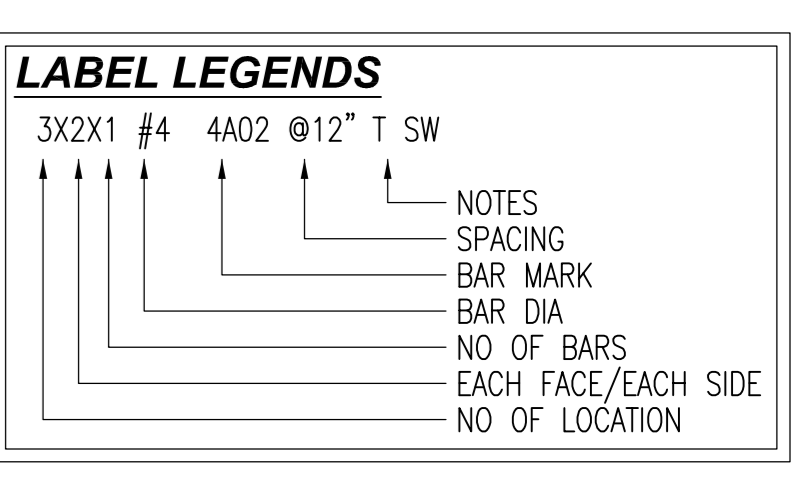

**REFERENCE DRAWINGS**

- FOR REBAR DETAIL OF LEVEL-1 SLAB ON GRADE TOP LONG WAY REFER DRAWING #R06
- FOR REBAR DETAIL OF LEVEL-1 SLAB ON GRADE TOP LONG WAY REFER DRAWING #R07
- FOR REBAR DETAIL OF LEVEL-1 SLAB ON GRADE TOP SHORT WAY REFER DRAWING #R08
- FOR REBAR DETAIL OF LEVEL-1 SLAB ON GRADE TOP SHORT WAY REFER DRAWING #R09
- FOR REBAR DETAIL OF LEVEL-1 SLAB ON GRADE BOTTOM LONG WAY REFER DRAWING #R10
- FOR REBAR DETAIL OF LEVEL-1 SLAB ON GRADE BOTTOM LONG WAY REFER DRAWING #R11
- FOR REBAR DETAIL OF LEVEL-1 SLAB ON GRADE BOTTOM SHORT WAY REFER DRAWING #R12
- FOR REBAR DETAIL OF LEVEL-1 SLAB ON GRADE BOTTOM SHORT WAY REFER DRAWING #R13